



KCB BANK (K) LIMITED

REQUEST FOR PROPOSAL

FOR

SUPPLY, INSTALLATION AND COMMISSIONING

OF

31.6kWp SOLAR PV SYSTEM

AT

MTWAPA BRANCH

EMPLOYER / CLIENT:

KCB BANK (K) LIMITED
P. O. BOX 48400 - 00100
NAIROBI

SERVICES ENGINEERS:

SERVCON ASSOCIATES LTD.
P.O BOX 5602- 00100
NAIROBI

DECEMBER 2024

SPECIAL NOTES

The Contractor is required to check the numbers of the pages of these Tender Documents against the contents stated on the Table of Contents and should he find any missing information, they must inform Bank via invitation Email and as described in this document at once and have the same rectified.

Should the Contractor be in doubt about the precise meaning of any item or figure for any reason whatsoever, he must inform the Bank via Email in order that the correct meaning may be decided before the date of submission of tenders.

No liability will be accepted nor any claim allowed in respect of errors in the Contractor's tender due to mistakes in these Tender Documents which should have been rectified in the manner described above.

KCB BANK (K) LIMITED.

PROVISION OF 31.6kWp SOLAR SYSTEM PROJECT FOR BANK BRANCH AT MTWAPA, KILIFI COUNTY

SECTION I: INVITATION TO REQUEST FOR PROPOSAL (RFP)

- 1.01 KCB Bank (Kenya) Ltd invites bids for the proposed 31.6kWp Solar PV System Project for their Bank premises in Mtwapa, Kilifi county
- 1.02 A complete set of tender documents will be shared via Oracle Fusion System
- 1.03 The Technical Proposal and Financial Proposal shall be returned via Oracle Fusion System
- 1.04 Prices quoted should be for the given Options A and B as described in the tender document, net inclusive of all taxes, must be in Kenya shillings and shall remain valid for 90 days from the closing date of tender.
- 1.05 Tenders shall remain valid for ninety (90) days from the final date for submission of Tenders stipulated in Paragraph 1.03 above, and no Tenderer may withdraw his tender within that period.
- 1.06 The Client shall not be bound to accept the lowest or any tender.
- 1.07 It shall be mandatory for the successful /awarded bidder to carry out site survey/visit to confirm particulars of the design before mobilization and execution of the works.
- 1.08 Delivery period of the project shall be proposed by the bidders
- 1.09 The words “Approved Tenderer” in these conditions shall mean that the Tenderer shall be approved by the Client as having complied with these Conditions in every respect.
- 1.10 The word “Tenderer” in these Conditions shall be deemed where applicable to include two or more persons. The word “his” may also mean “their” and the word “he” may also mean “they”.
- 1.11 If it is found on the examination of a Tender that there is any discrepancy between the Total Amount of the Tender and the amount arrived at by valuing the Priced BoQ at the rates or prices set against them by the Tenderer, then the figure shall be corrected arithmetically and the differences between the Tender and the corrected total shall be applied as a percentage adjustment or addition or omission on all the rates, so that the original Tender Amount remains unaltered. When calculating the percentage adjustment, the total cost of the Preliminaries, Provisional and P.C Sums, Contingencies and any other items of a similar nature shall be excluded.
- 1.12 If it is found on examination, that any rates for the work appear to be unreasonable then the attention of the Tenderer shall be drawn to any such items. If as a result of this the Tenderer asks for any rates to be changed, then the arithmetical effect of any change will be adjusted in accordance with sub-paragraph 1.15 above.
- 1.13 Non-compliance with the above Conditions in any respect shall render the Tender liable to rejection.

These notes shall form part of these specifications and conditions.

OPTION A - OUTRIGHT PURCHASE

FORM OF TENDER

**To: KCB BANK (K) LIMITED.
P.O BOX 48400-00100
NAIROBI.**

Sirs,

**RE: KCB – MTWAPA BANK BRANCH, KILIFI COUNTY
SUPPLY AND INSTALLATION OF 31.6kWp SOLAR SYSTEM PROJECT**

We offer to execute the whole of the above-mentioned works required in the erection and completion of the above-mentioned works all in accordance with the Drawings, Specifications and Bills of Quantities for the sum of Kshs. _____ in words, Kenya Shillings _____

We are also willing to enter into a contract with the Client and to complete the whole of the works within the time stipulated below;

Completion PeriodWEEKS from the date of contract signing.

We agree that the Client shall not be bound to accept the lowest or any Tender and that no expenses incurred by us in preparation of this Tender will be allowed.

We submit the name of _____ as Surety who has signed the form attached and is willing to be bound to the Client in a sum equal to ten per cent (10%) of the Contract Sum for the due performance of the Contract up to the Certified Date of Practical Completion and who will, when and if called upon, sign to that effect on a Form of Bond which has been inspected by our Surety (without the addition of limitations) on the same day as the Contract Agreement is signed. In the event of the Surety named herein not being approved by the client or not completing the Bond for any reason, the undersigned agreed to furnish, within seven days, another Surety to the Client’s approval.

We agree that this Tender shall remain valid for, and shall be not withdrawn within, ninety days from the final date for submission of Tenders and in the event of your acceptance, to execute a formal Contract Agreement with the Main Contractor.

**SIGNATURE.....
(Tenderer)**

**SIGNATURE
(Witness to Tenderer)**

NAME

NAME

ADDRESS

.....

DATE

DATE

OPTION B - LEASE TO OWN

FORM OF TENDER

**To: KCB BANK (K) LIMITED.
P.O BOX 48400-00100
NAIROBI.**

Sirs,

**RE: KCB – MTWAPA BANK BRANCH, KILIFI COUNTY
SUPPLY AND INSTALLATION OF 31.6kWp SOLAR SYSTEM PROJECT**

We offer to execute the whole of the above-mentioned works required in the erection and completion of the above-mentioned works all in accordance with the Drawings, Specifications and Bills of Quantities for the sum of

Kshs. _____ in words, Kenya Shillings _____

We propose the quarter payment as detailed below;

Lease-to-Own	3-Year Option	5-Year Option	7-Year Option
Fixed Quarterly (every 3-Months) fee (KES)			

Completion PeriodWEEKS from the date of contract signing.

We agree that the Client shall not be bound to accept the lowest or any Tender and that no expenses incurred by us in preparation of this Tender will be allowed.

**SIGNATURE.....
(Tenderer)**

**SIGNATURE
(Witness to Tenderer)**

NAME

NAME

ADDRESS

.....

DATE

DATE

FORM OF UNDERTAKING

**To: KCB BANK (K) LIMITED.
P.O BOX 48400-00100
NAIROBI.**

Sirs,

**CONTRACT: KCB - MTWAPA BANK BRANCH, KILIFI COUNTY
SUPPLY AND INSTALLATION OF 31.6 kWp SOLAR SYSTEM PROJECT
FORM OF UNDERTAKING**

Weof

are willing to act as Surety and to be bound to the Client in the sum equal to Ten percent (10%) of the Contract Sum, for the due performance by (Tenderer) of
.....
.....

of a Contract, which he/they contemplate(s) entering into a Contract with the Bank for the supply, installation, testing and commissioning of the Solar PV system Installation as described in this document, and the accompanying relevant drawings for the said Bank branch, according to the Form of Bond, a copy of which has been inspected by us without addition of any limitations.

We agree to enter into a Bond under the above-mentioned terms when and if called upon to do so.

Signature (Surety)

Date

Witness

To be completed by proposed Surety and returned with Tender Documents.

KCB BANK (K) LIMITED.

PROVISION OF 31.6kWp SOLAR SYSTEM PROJECT FOR BANK BRANCH AT MTWAPA, KILIFI COUNTY

BILL NO. 01 - PRELIMINARIES AND GENERAL CONDITIONS

1. NAMES OF PARTIES

The following will be inserted in the Articles of Agreement: -

Employer: KCB BANK (K) LIMITED.
P.O BOX 48400-00100
NAIROBI.

Electrical/Mechanical Engineers SERVCON ASSOCIATES LIMITED
Consulting Services Engineers
P. O. Box 5602 - 00100
NAIROBI.

For the purposes of these works the Electrical/Mechanical Engineers shall be a representative of, and act on behalf of the Engineers except where variation orders are to be issued.

2. DEFINITIONS OF TERMS

The terms, phrases and abbreviations shall be deemed to have the following meanings wherever used hereinafter and in all Contract Documents

'**Engineer**' shall in the case of Electrical/Mechanical works mean Servcon Associates Ltd of P. O. Box 5602 -00100 Nairobi and, in the case of Civil and or Structural works, shall mean the Civil and or Structural Engineer appointed for works, or in the event of any of their deaths, or ceasing to be the Engineers for the purposes of this Contract, such other person as the Employer shall nominate for that purpose. For the purpose of Civil, Structural, Mechanical and Electrical engineering works the Engineer shall be deemed vested with the duties of and be the representative of the Engineer, except in respect of variations which involve the Contract Sum.

'**Main Contractor**' shall mean the person or persons, partnership, firm or company, whose tender for the Main Contract has been accepted, and who has or have, signed the main contract and shall include his or their heirs, executors, administrators, assigned successors and duly appointed representatives. For the purposes of this work, the terms "Main Contractor", "Contractor" and "Contractor" shall have the same meaning.

'**Works**' shall mean all or any portion of the work, material and articles, wherever the same are being manufactured or prepared, which are to be used in the execution of this Contract and whether the same may be on the site or not.

'**Approved**' shall mean approved by the Engineer/Engineer at his absolute discretion.

'**Directed**' shall mean directed by the Engineer/Engineer at his absolute discretion.

'Selected' shall mean selected by the Engineer/Engineer at his absolute discretion.

'm³' shall mean cubic metre.

'm²' shall mean square metre.

'm' shall mean linear metre.

'mm' shall mean linear millimetre.

'kg' shall mean kilogram

'No' shall mean Number.

'Prs' shall mean Pairs.

'B.S.' shall mean the current British Standard Specification published by the British Standards Institution, 2 Park Street, London, W.I., England.

'K.S.' shall mean the current Kenya Standards Specification published by the Kenya Bureau of Standards.

'As before' shall mean in all respects as earlier described in the same or previous Bill.

'Ditto' shall mean the whole of the preceding description except as qualified in the description in which it occurs. Where it occurs in descriptions of succeeding items it shall mean the same as in the first description of the series in which it occurs except as qualified in the description concerned. Where it occurs in brackets it shall mean the whole of the preceding description which is contained within the appropriate brackets.

'Fix Only' shall mean take delivery on site (unless otherwise stated), unload where necessary, transport within site compound, store, unpack, check contents against orders and packing lists, assemble as necessary, distribute to position, hoist and fix only.

3 TENDER CONDITIONS

Any act of collusion which may distort normal competitive conditions may cause the rejection of the tenders concerned. By participating in the tendering, tenderers certify not to be involved in such acts of collusion.

Tenders containing abnormally high or abnormally low unit prices and/or lump sums may be rejected. Before such rejection, however, the Contractor will be given the opportunity of providing a detailed explanation.

Tenders must be returned complete and will be opened, in the presence of tenderers, or their assigned representatives at the time and venue stated in the letter of invitation to tender. Incomplete tenders or tenders received after the stated time will be returned unopened.

Tenders are invited in strict accordance with the documents issued, counter offers submitted with tenders will not be considered, letters of qualification with tenders may be ignored if they have the effect of modifying either the terms of a tender or the compatibility of a tender with other tenders. Should a tenderer, in good faith, wish to propose modifications to the tender terms, conditions and contents for the purposes of reducing the tender amount, then he shall contact the Engineer in writing well before the date of tender opening. Should the proposed modification be approved by Consultants

and Employer all tenderers will be advised in due time for the modification of their tenders. No proposed modification will be considered unless this procedure has been adopted.

The Employer is not bound to accept the lowest or any tender, nor is the Employer bound to divulge reasons for the acceptance or non-acceptance of any tender. Any tender may be accepted by the Employer within the stated period unless previously withdrawn by the tenderer.

All deletions, additions and corrections to figures inserted in the tender documents are to be signed by the tenderer.

4. DESCRIPTION OF SITE

The site of the works shall be in KCB Mtwapa Branch, Kilifi County.

The Contractor is recommended to visit the site and will be deemed to have satisfied himself with regard to the relevant details of preliminary. If the Contractor, for whatever reason, feels specialized attendance will be required, with significant financial implications, or requires specialized mobilization to start the works, he should spread the cost of such works in his unit rates. No claims whatsoever by the Contractor for additional payment will be allowed on the grounds of any misunderstanding or misapprehension in respect of any such matters or otherwise, should the Sub- Contractor be required to offer specialized attendance prior to, or during, the performance of the Contract.

In case of difficulty in locating the site, the tenderer should contact the Engineer who will give relevant direction.

5. DESCRIPTION OF THE WORKS MEASURED IN THE BILLS OF QUANTITIES

The works are measured and described in the Bills of Quantities comprising the following: -
Supply, installation, setting to work to the entire satisfaction of the Engineer all Solar installation system as set out in the Bills of Quantities and as per the attached drawings.

6. TENDER EVALUATION PROCEDURES

The bidders are required to submit their documentation in the format as listed in the evaluation criteria below;

EVALUATION CRITERIA

A. Compliance to Mandatory Requirements

The first stage of the evaluation will involve determination of responsiveness to the Mandatory Requirements of the request for proposal and will include:

Mandatory requirements:

- a) Certificate of registration/Incorporation,
- b) Valid/Current Tax Compliance Certificate from relevant Authorities where the business operations of tenderer are domiciled,
- c) CR12 (issued within the last 6 Months) or equivalent to show names of Directors of the tendering company /vendor.
- d) Identification documents [copy of ID] for all Directors/owners of the company.

- e) Provide valid copy of Solar PV installation registration certificate from the Energy and Petroleum Regulatory Authority (EPRA) (Class C1) for the vendor.
- f) Provide valid copy of Electrical engineering Services registration certificate from National Contracting Authority- NCA (Class 4 or above) for the vendor.
- g) Summary of previous Vendor Experience including a copy of either LPO, Award letter or Contracts, indicating details/name of the project, start and end dates of the project or ongoing, the client's name and address, contract amount and details of the contact person including, designation, name, telephone No and email.
- h) Proposed project personnel indicating Name, age, academic and professional qualifications, experience indicating firm/project, duration, designation, and professional membership if any for all proposed personnel.
- i) Duly certified and stamped Curriculum Vitae (CV) and copies of certificates for the proposed project lead for the assignment including a certified copy of the EPRA T3 license and signed undertaking of availability for the assignment.
- j) Valid business permit or its equivalent duly authorized and certified.

Tenderers who do not satisfy any of the above requirements shall be considered **non-responsive** and their tenders will not be evaluated further.

Bidders who satisfy all mandatory requirements will be progressed to the Technical Evaluation

B. Compliance with Technical Requirements

Proposals meeting all the mandatory requirements will be subjected to Technical Evaluation based on the criteria given below:

NO	EVALUATION CRITERIA	CRITERIA	SCORE
1.	Bidder to provide Manufacturer Letter of Authority for Inverters, Storage system, Solar PV modules and Mounting Structures received within a month of the bidding period and addressed to Head of Supply Chain Management, KCB Bank Kenya Ltd	Score 2mks for each Manufacturer's Authorization Letter / Dealership Agreement	8
2.	Clearly defined and documented Health and Safety Policy and Plan. Must be signed within a month of the bidding period.	Score 3 for signed documented H&S policy within stipulated time and signed. Otherwise Score 0.	3
3.	The Vendor to provide evidence of EPRA license for Installation of Solar PV systems, EPRA License C1, EPRA electrical Contractor license B or above and NCA 4 or above electrical engineering license	Score 2 marks for each license	6

4.	Project Implementation Plan	Score 10 if bidder provides a clear programme of work indicating key milestones for the long lead items and has also indicated the Delivery Timeline for the whole project to be 3 Months or below and with an attached proposed plan using a project scheduling software Score 5 if bidder provides project delivery timeline of between 4 months to 6 months, otherwise score 0.	10
----	-----------------------------	---	----

5.	Organizational structure with at least 4 levels of organization : Director, PM, Site Managers, Workmen	Score 6 if Structure with 4 levels Director, PM, site manager and Workmen. Score 4 if Structure with 3 levels Director site managers and workmen staff only. Score 3 if Structure with 2 levels Director and workmen staff only Score 0 if no structure provided.	6
6	Proof of supplier equipment warranty (Panels, inverters, and Storage Systems) and existence of local support of equipment intended to be supplied under scope of works	If bidder has provided warranties of at least 25 years for panels, 10 years for inverters and storage system (after commissioning) and can be able to offer local support on items supplied score 4 (per item).	12
7.	Proof of bidder's system warranty and existence of local support of equipment intended to be supplied under scope of works	If bidder has provided warranty of at least 10 years (after Commissioning) and can be able to offer local support on items installed (per item).	3
8	Curriculum Vitae of Lead Engineer with minimum Specific work experience of 5 years and holder of at least a Degree in Mechanical/Electrical Engineering or Renewable Energy or equivalent and EPRA T3 license [Provide evidence as owner or employee of the vendor]	Score 7 for qualified lead engineer (with T3 EPRA License) and over 5 years' specific experience. Score 2 for qualified lead engineer (with T3 EPRA License) with less than 5 years. Score 0 if missing T3 EPRA License.	7
9	Proof (award letters or completion certificates) of previously undertaken supply and installation of Solar Projects with not less than 20kw. State at least 5 sites completed in the last three years [2021-2024]	Score 2 for each Proof (award letters or completion certificates) of previously undertaken supply and installation of Solar Solution to a maximum of 10mks	10

SN	Component	<i>Bidders to submit product brochures/details from manufacturer showing compliance to the specifications below</i>	Bidder Remarks
10	Solar PV Modules	<ul style="list-style-type: none"> Score 5 for Fully compliant, 2.5 for partial compliant and score 0 for noncompliant 	5
11	Energy Storage (Battery Bank)	<ul style="list-style-type: none"> Score 5 for Fully compliant, 2.5 for partial compliant and score 0 for noncompliant 	5
12	Inverter	<ul style="list-style-type: none"> Score 5 for Fully compliant, 2.5 for partial compliant and score 0 for noncompliant 	5
13	Roof Mounting Structure	<ul style="list-style-type: none"> Score 5 for Fully compliant, 2.5 for partial compliant and score 0 for noncompliant 	5
14	Lightening protection system and Earth Protection Scheme compliance	<ul style="list-style-type: none"> Score 2.5 for each Fully compliant, 2.5 for partial compliant and score 0 for noncompliant 	5
15	Remote Monitoring system with details on the plant yield, faults and plant trouble shooting The system should be configurable/installable on mobile phones as well, a minimum of 10 users.	<ul style="list-style-type: none"> Score 10 for Fully compliant, 5 for partial compliant and score 0 for noncompliant 	10
		TOTAL SCORE (OUT OF 100%)	100

The contractor will be required to score a minimum of **70% and above** on the technical Evaluation to qualify to have their financial bids opened for evaluation.

For Financial Proposal, following the return of the tenders for the works measured in these Bills of Quantities, arithmetical and other analysis will be carried out in order to select the lowest acceptable tender in terms of responsive and realistic pricing, etc.,. This selection will be at the sole discretion of the Client.

The resultant total, together with the priced Preliminaries and any modified Prime Cost and Provisional Sums, will be consolidated into a sum for which the Contract will be signed.

This procedure will be applied only to the selected tender and no other tender will be considered. Neither the Client nor the Consultants will enter into discussion or correspondence with the other tenderers after the selection process has been carried out and no reasons will be given for selection or non-selection.

Any tenderer unable to comply with these procedures will be disqualified from the selection process.

7. ACCESS TO SITE AND SECURITY

Means of access to the site will be as directed by the Engineer; no other access will be permitted in any circumstances.

Access to the site will be continuously controlled by the Client and the owners of the building and the Contractor will have to comply with the requirements of the Client and the Landlords as to the searching of vehicles and personnel on entry and exit from the site.

8. AREA TO BE OCCUPIED BY THE CONTRACTOR

The areas to be occupied by the Contractor for use as storage or for erection of workshop etc, will be as directed by the Client and/or the Engineer. The Contractor must confine his activities strictly to the areas so marked and must ensure that his workmen do not trespass on the adjoining property or cause inconvenience to its occupiers.

9. DRAWINGS

- 9.1 The Contractor will be deemed to have examined the drawings before tendering and to have satisfied himself regarding their details and regarding the nature and extent of the works and the method of installation involved. No claims arising out of misapprehension in these respects will be allowed.
- 9.2 The Contractor shall at his own risk and cost execute and perform the Works described in the conditions of Contract and Bills of Quantities and detailed in the drawings provided and supplied to the Contractor for the purpose of Works and completely finish the said works in a good workmanship and with the utmost expedition.
- 9.3 The Contractor shall satisfy himself as to the correctness of all Drawings and measurements. If the Contractor finds any discrepancy in the Drawing or between the Drawing and the Specification and bills of Quantities he shall immediately refer the same to the Engineer who will decide which shall be followed. Figured dimensions shall be taken in preference to the scale mentioned on or attached to any Drawing. Details shown on Drawing shall be taken in preference to items and quantities in the Specification.
- 9.4 Two copies of all drawings and of the specification will be furnished free of cost to the Contractor (whose tender has been accepted) for his own use.

10. VALUATION OF LUMP SUM PRELIMINARY COSTS

Lump sums entered in these Bills of Quantities against any item of General Condition or Preliminaries will be included in appropriate valuations according to reasonable assessment of actual costs involved in the item. Any balance between this assessment and the actual sum entered in the Bills of Quantities will be included in subsequent valuations as monthly installments over the balance of the Contract Period.

In the final payment, however, the works done will be re-measured and the Contractor shall be paid only for the actual work done irrespective of what is entered in the tendered quantities or lumpsum provisions.

11. PAYMENT FOR MATERIALS ON SITE

All materials for incorporation in the works must be stored on or adjacent to the site before payment is effected, unless specifically exempted by the Engineer/Employer. This is to include the materials of the Contractor, and his Nominated Suppliers.

12. CONTRACT AGREEMENT AND CONDITIONS

12.1 General

The Articles of Agreement and conditions shall be the 'Agreement and Schedule of Conditions of Building contract Form published by the Kenya Association of Building and Civil Engineering Contractors'. Where there is ambiguity in interpretation FIDIC Conditions of Engagement (Latest Edition) shall form a complementary and over-riding reference.

12.2 Water and Electricity Supply

Water and electrical power will be made available by the Client to the Contractor. The Client and the Contractor will mutually agree whether or not the latter should pay for the water/electricity used for the works.

12.3 Contractor's Materials

Purchase of materials by the Contractor and their storage on site for inclusion in payment certificates far in advance of reasonable requirements will be allowed.

12.4 Storage of Materials

Storage space will be provided by the Main Contractor. However, the Contractor shall provide, at his own risk and cost, where directed on site, weatherproof lock-up sheds for the safe storage and custody of materials for the works and for the use of workmen engaged therein and shall remove such sheds and make good damage or disturbed surfaces upon completion to the satisfaction of the Engineer/Engineer.

The Contractor shall be liable for the cost of any storage accommodation.

13. WARRANTY AND PERFORMANCE STANDARDS

The Contractor must furnish the Employer through the Engineer with a general written warranty covering quality of workmanship, material and equipment and be compelled thereby for a one year period after practical completion of the Contract.

The Contractor must make good, at his own expense, such repairs and replacements as may be required as a consequence of negligent workmanship or defective materials. The Contractor must also procure such warranties and guarantees as aforesaid from all manufactures and/or suppliers of materials or equipment incorporated in the project under this Contract.

The Contractor must comply in all respects with given standards of workmanship as defined and described in the Specifications and Bills of Quantities and relevant Codes of Practice. The Contractor must also comply with all tests of materials as required and/or as directed by Engineer.

14. TOOLS, PLANTS, ETC

The Contractor shall allow for providing all ladders, tools, plant and transport required for the works, except in so far may be specifically stated otherwise.

15. SAFETY, HEALTH AND WELFARE OF WORKPEOPLE

The Contractor shall allow for providing for the safety, health and welfare of workpeople and for complying with any relevant Ordinances, Regulations or Union agreement.

16. NATIONAL INSURANCE AND PENSIONS

The Contractor shall allow for making any National Social Security Fund payments due in respect of workpeople.

17. HOLIDAY AND TRANSPORT OF WORKPEOPLE

The Contractor shall allow for providing holidays and transport for workpeople and for complying with any relevant Ordinances or Union Agreement.

18. EXISTING PROPERTY

The Contractor shall take every precaution to avoid damage to all existing property including flower beds, fences, roads, cables, drains adjacent buildings and other services and he will be held responsible for all damage arising from the execution of this Contract to the afore-mentioned property and he shall make good all such damage where directed at his own expenses to the satisfaction of the Engineer/Engineer.

19. TESTING

The Contractor shall allow for all testing of material and installations required by these Specifications and he shall be responsible for all expenses incurred in completing such tests, including costs of materials and labour, equipment, transport and all other costs.

20. SUPERVISION AND WORKING HOURS

The Works shall be executed under the direction, and to the entire satisfaction in all respects, of the Engineer/Engineer who shall at all times during normal working hours have access to the works and to the yards and workshops of the Contractor or other places where work is being prepared for the Contract.

The working hours shall be those generally worked by good employers in the Building and Civil Engineering Trades in gazetted holidays unless the Engineer shall so direct.

No work shall be covered up in the absence of the Bank representative or without the prior approval of the Engineer in writing.

21. SAMPLES

The Contractor shall furnish at his own cost any samples of materials or workmanship that may be called for by the Engineer for his approval or rejection and any further samples in the case of rejection until such are approved by the Engineer, and the Engineer may reject any materials or workmanship not in his opinion up to the approved samples.

The Engineer shall arrange for the testing of such materials as he may at his discretion deem desirable but the testing shall be made at the expense of the Employer and not at the expense of the Contractor unless the materials fail to pass the test or are in the opinion of the Engineer not in accordance with the specification, in either case the Contractor shall pay for testing in accordance with the current scales of testing charges of approved testing authorities.

The procedure for submitting sample of materials for testing and the method of marking for identification shall be laid down by the Engineer.

The Contractor shall allow in his Tender for such samples and tests.

22. MATERIALS, TOOLS, PLANT ETC.

All materials and workmanship used in the execution of works shall be of the best quality and description unless otherwise described. Any materials for the works condemned by the Engineer shall immediately be removed from the Site at the Contractor's expense.

The Contractor shall provide at his own risk and cost all materials, scaffolding, tools, plant, transport and workmen required for the Works, insofar as may be stated otherwise herein.

The Contractor shall order all materials to be obtained from overseas immediately after the Contract is signed and shall also order materials to be obtained from local sources as early as necessary to ensure that such materials are on Site when required for use in the Works.

Any defects which may appear, either of materials or of workmanship, during the defects liability period provided by the Contract, shall be made good by the Contractor at his own expense, as and when directed.

If the Contractor shall fail to carry out such order, as by the preceding paragraph provided, within such reasonable time as may be specified in the order, the material or work affected may be made good by others in such manner as the Engineer may direct, in which case the cost thereby incurred shall, upon the written certificate of the engineer, be recovered by the Contractor as a liquidated damage in money.

If any defect be such that it shall be impracticable or inconvenient to remedy the same, the diminution in the value of the works due to the existence of such defect shall be deducted from the sum remaining to be paid to the Contractor or failing such remainder, shall be recovered as a liquidated damage in money.

23. FOREMAN

The Contractor shall keep constantly on Works a competent English-speaking foreman and any directions or explanations given by the Engineer/Engineer to such foreman shall be deemed to have been given to the Contractor.

24. INSURANCE

The Contractor shall, during the execution of the Works, insure himself and keep himself insured against all liability under the Workmen's Compensation Act or any amendment thereto for accidents to workmen employed by him on the said works and shall hold the Employer and all parties to the contract harmless in respect of any such accidents to any such workmen. The Contractor shall further insure himself and keep himself insured against all liability arising from all Third Party Claims arising from accidents and he shall hold the Employer and all parties to the contract harmless in respect of any such accidents.

No payments on account of the work executed will be made to the Contractor until he has satisfied the Engineer either by the production of an Insurance Policy or an Insurance Certificate that the foregoing provisions have been complied with in all respects.

Thereafter the Engineer shall from time-to-time check that premiums are duly paid up by the Contractor who shall, if called upon to do so, produce receipts of premium renewals for the Engineer's inspection.

25. BOND

The Contractor shall find and submit for the approval of the Client the name of one surety who shall be an established Bank, Insurance Company or Fidelity Guarantee Corporation and who will be willing to be bound to the contractor in an amount equal to ten percent (10%) of the Contract amount for the due performance of the Contract upto the date of completion as certified by the Engineer and who will when and if called upon, sign a Bond to that effect, on the same day as the Contract Agreement is Signed.

In the event of the Surety named not being approved by either the Client, the Contractor shall furnish within seven days another surety to the approval of the Client.

26. TIME FOR COMPLETION AND LIQUIDATED DAMAGES

The Contractor shall proceed with the works in such manner and in such order as the Engineer shall direct so as to complete the Works in the shortest possible time.

It is the responsibility of the Contractor to ensure that all material, fittings, equipment and items to be supplied are ordered and delivered to the site ready for installation at such times as to cause no hold up to the programme of work.

- NOTE:** 1. The Contract Completion period is as stated in Contract.
2. Liquidated damages and Ascertained Damages will be calculated pro-rata on the rate provided in the Contract.

27. PAYMENT AND CERTIFICATES

Payments shall be made directly to the sub contractors through the Main Contractor or as otherwise advised. All payments shall be less retention as specified in the Contract Agreement. The Contractor shall be paid only for work done and/or materials on site. If other forms of payment are found to be more acceptable and agreed upon they shall be stated in the Contract Agreement.

The percentage of certified value retained shall be 10%. Limit of Retention shall be a sum equivalent to 5% of the Contract Sum.

No Certificate so issued by the Engineer shall of itself be considered conclusive evidence as to the sufficiency of any work or materials to which it relates so as to relieve the Contractor from liability to execute the Works in all respects in accordance with the terms and conditions of this agreement or from his liability to make good all defects as provided thereby.

28. CONDITIONS OF CONTRACT, ETC

The Contract Agreement shall be based on KABCEC conditions. FIDIC conditions for electrical and mechanical works shall form complimentary and over-riding reference where clear interpretation can not be made.

Copies of the (FIDIC) Conditions of Contract for Electrical and Mechanical Works, Third Edition 1987, may be seen at the office of the Engineer during normal office hours on any working day until the time for the submission of tenders.

29. BLASTING

Blasting will not be allowed whatsoever.

30. HOISTING

The Contractor is referred to the Drawings and to the general description of the building. Throughout these specifications generally no mention is made of heights for hoisting. All prices must include for hoisting and fixing at any level within the limits shown on the Drawings or included in the general description of Works. Where a particular level is specified the Contractor shall price accordingly.

31. CASING UP AND PROTECTING

The Contractor shall be responsible for casing up or otherwise protecting to the satisfaction of the Engineer/Engineer all parts of the Contract Works liable to cause injury and for removing such protection and making good on completion.

32. WORKS TO BE DELIVERED UP CLEAN

On completion of the Works, the site and the Works shall be cleared of all plant, scaffolding, rubbish and unused materials and shall be delivered up in a clean and perfect condition in every respect to the satisfaction of the Engineer/Engineer.

33. DEFECTS LIABILITY PERIOD

The Defects Liability Period shall be as provided in the Contract.

34. CLAIMS FOR EXTRAS

The Contractor shall submit to the Engineer claims for any work or circumstances on account of which he may consider that he is entitled to extra payment within seven days from the time of commencement of such work or occurrence of such circumstances. Any such claim must be in writing and accompanied by full particulars and must state which provision of the Contract it is claimed that payment shall be made.

35. TRADE NAMES

Where trade names of manufacturer's catalogue numbers are mentioned in these specifications the reference is intended as a particular requirement by the client to the type of the article or material required. The Contractor may use any article or material equal in type or quality to those therein described subject to the prior approval of the Engineer /Engineer, and at his (the Engineer's/Engineer's) absolute discretion. The onus of proof as to equivalent quality will rest with the Contractor, who's Tender will be deemed to include for the makes described hereafter.

36. FLUCTUATIONS

This is a fixed price Contract and no claims will be allowed on fluctuations. The Tenderer's prices will be deemed to have allowed for forecasts on fluctuations.

BILL NO. 1 - PRELIMINARIES AND GENERAL CONDITIONS

SUMMARY

KShs.

Cts.

B/F from Page No. 1-1

B/F from Page No. 1-2

B/F from Page No. 1-3

B/F from Page No. 1-4

B/F from Page No. 1-5

B/F from Page No. 1-6

B/F from Page No. 1-7

B/F from Page No. 1-8

B/F from Page No. 1-9

B/F from Page No. 1-10

B/F from Page No. 1-11

B/F from Page No. 1-12

B/F from Page No. 1-13

B/F from Page No. 1-14

Total Carried Forward to Main Summary Page

SECTION 5

PART 1

**GENERAL TECHNICAL SPECIFICATIONS
FOR
SOLAR PV SYSTEM INSTALLATION**

TABLE OF CONTENT

TECHNICAL SPECIFICATION FOR SOLAR PV INSTALLATIONS.....	1
GENERAL SPECIFICATIONS FOR SPV PLANTS	1
SITE CONDITIONS.....	2
SOLAR-PV MODULES	2
BOLTS AND NUTS FOR FASTENING SOLAR MODULES.....	5
INSTALLATION OF ARRAY STRUCTURE.....	7
ORIENTATION AND TILT OF THE PV ARRAY	7
SOLAR ARRAY (PV) DISCONNECTS SWITCH.....	8
ELECTRICAL WIRING	8
CABLES AND INTERCONNECTIONS	9
SOLAR METER AND NETMETER.....	9
SOLAR METER:.....	9
NETMETER:.....	9
GROUNDING AND LIGHTNING PROTECTION	10
THE DC-AC INVERTER.....	12
AC SYSTEM SPECIFICATIONS	13
WARRANTY	16
OPERATION MANUAL	17

SECTION 5-1: TECHNICAL SPECIFICATION FOR SOLAR PV INSTALLATIONS

1.0. SOLAR –PV SYSTEM SPECIFICATIONS

This section covers the specification of works which include guidelines and practices for the Supply, Installation, Testing and Commissioning of Solar PV power plants (Roof-top/Ground Mounted). The modules, panels and array shall be referred to as Solar-PV modules, -panels and - array respectively.

Solar PV power plant system comprises of monocrystalline Silicon/ Thin Film Solar PV modules with intelligent Inverter having MPPT technology and Anti-Islanding feature and associated power electronics, which feeds generated AC power to the branch load. Other than PV Modules and Inverter/Inverters, the system consists of Module Mounting Structures, appropriate DC and AC Cables, Array Junction Boxes (AJB) / String Combiner Boxes (SCB), AC and DC Distribution Box, Lightning Arrester, Earthing Systems, Net meter, etc.

2.0 GENERAL SPECIFICATIONS FOR SPV PLANTS

The technical characteristics of all hardware must comply with the Technical Specifications herein, and the specified scope.

Structural Robustness: All components of the Solar-Photovoltaic (SPV) power plant shall be robust, neatly assembled, firmly fixed supports in ground/roof and designed to allow easy access using adequate tools. The SPV power plant shall have a minimum useful life of 20 years (80% power output), with solar modules warranted for 2 years.

Protection against Corrosion and rusting: All components and accessories shall be made from corrosion resistant material and made good to be rust-free by galvanizing and or painting of all surfaces. that are exposed to the ambient conditions. All materials shall be resistant to effects of excessive moisture, water, and ambient temperature. Resistance to corrosion shall be according to DIN 8985 standards.

Protection against thefts: All equipment, parts and accessories shall be well fastened against theft, with considerable difficulty to un-screw the solar modules or metal parts from the entire assembly.

3.0 ABBREVIATIONS

For the purposes of these Technical Specifications, the following abbreviations shall apply:

- **AC:** Alternating Current, **D.C:** Direct Current, **DOD:** Depth of discharge.
- e.m.i.: Electromagnetic interference
- **kWp:** Kilo Watt-Peak
- **MCB:** Miniature circuit-breaker
- **NOCT:** Normal Operating Cell Temperature (*Irradiance level: 1000W/m² , Ambient temperature: 20°C,*
- AM1.5 spectrum, wind velocity: 1m/s)
- **PV:** Photovoltaic
- **SOC:** State of charge
- **STC:** Standard Test conditions (*Irradiance level: 1000W/m², Ambient temperature: 25°C, AM1.5 spectrum*)
- **SPV:** Solar Photovoltaic
- **SPVP:** Solar Photovoltaic Power
- **Wp:** Watt-Peak

4.0 SITE CONDITIONS

When designing and installing the system, the following precaution shall be taken into account.

- It should be noted that the sites lies within the tropics; hence the solar panels require a south/north facing location pointing to the equator.

5.0 SPECIFICATIONS OF SOLAR-PV MODULES, PANELS AND ARRAY

5.1 General Electrical and Mechanical Performance

The following forms a guide on the equipment specifications required for this project. The bidder MUST provide on supply, the equipment datasheets detailing equipment characteristics and features. Only certified Mono-crystalline silicon modules are generally acceptable. The modules should be certified for compliance with the following specifications:

- International Electro-technical Commission (IEC) 61215/61646 - 1993, Crystalline silicon terrestrial photovoltaic (PV) modules - Design qualification and type approval (or most recent edition) 1 Number of thunderstorm days per year
- BS standard US-469: Crystalline silicon terrestrial photovoltaic (PV) module -Design qualification and type approval (US-469:2005, 1st edition)
- BS standard US-564: Crystalline silicon terrestrial photovoltaic (PV) module - Design qualification and type approval (US-564:2005, 1st edition)

5.2 Solar-PV Modules

These shall be constructed from high efficiency mono or multi-crystalline silicon with minimum cell efficiency of 16%. Crystalline silicon cells and modules to be supplied shall be approved to IEC 61215 standards with an EN-ISO certificate, JCRC-ISPRA 503, PV-GAP, UL listing 1703, NEC 2008 compliant or similar quality type approval. The pertinent conditions are solar irradiance of 1000W/m², Normal Testing Conditions (STC), Normal Operating Cell Temperature (NOCT) of 25°C.

The specifications for the PV Module is detailed below:

1. The PV modules must be PID compliant, salt, mist & ammonia resistant and should withstand weather conditions for the project life cycle.
2. The back sheet of PV module shall be minimum of three layers with outer layer (exposure to ambience) and shall be made of PVDF or PVF. The Back sheets for PV Module with 2 layered or 3 layered Polyester types or the back sheets with Polyester (PET type) at Air side material are not permitted for the empanelment; The minimum thickness of the core layers (without adhesive and inner EVA coated) must be 300 microns. The maximum allowed water vapor transmission rate shall be less than 2 g / m²/day and shall have a Partial Discharge $\geq 1500V$ DC
3. The front glass shall meet the following specifications:
 - a) The facing glass must be Tempered, PV grade with Low iron and high transmission.
 - b) The transmission shall be $> 93\%$
 - c) Thickness shall be min 3.2 mm
 - d) Textured to trap more light
 - e) The glass shall have an Anti-reflective coating for the better transmission and light absorption.
 - f) Tempered glass to meet the external load conditions

4. The encapsulant used for the PV modules should be UV resistant in nature. No yellowing of the encapsulant with prolonged exposure shall occur. The sealant used for edge sealing of PV modules shall have excellent moisture ingress Protection with good electrical insulation and with good adhesion strength. Edge tapes for sealing are not allowed.
5. Anodized Aluminum module frames of sufficient thickness shall be used which are electrically & chemically compatible with the structural material used for mounting the modules having provision for earthing.
6. UV resistant junction boxes with minimum three numbers of bypass diodes and two numbers of MC4 connectors or equivalent with appropriate length of 4 sq.mm Cu cable shall be provided. IP67 degree of protection shall be used to avoid degradation during Life. .
7. Shading correction/ bypass diode for optimizing PV out to be incorporated in each solar module or panel level.
8. Each PV module used in any solar power project must use a RF identification tag (RFID), which must contain the following information. The RFID can be inside or outside the module laminate but must be able to withstand harsh environmental conditions.
 - a) Name of the manufacturer of PV Module.
 - b) Name of the manufacturer of Solar cells.
 - c) Month and year of the manufacture (separately for solar cells and module).
 - d) Country of origin (separately for solar cell and module).
 - e) I-V curve for the module.
 - f) Peak Wattage, IM, VM and FF for the module.
 - g) Unique Serial No. and Model No. of the module.
 - h) Date and year of obtaining IEC PV module qualification certificate.
 - i) Name of the test lab issuing IEC certificate.
 - j) Other relevant information on traceability of solar cells and module as per ISO 9000 series.
9. The following details should be provided on the module
 - a) Name of the manufacture.
 - b) Month and year of manufacture.
 - c) Rated Power at STC.
 - d) VMP, IMP, VOC, Isc.
10. The successful bidder shall arrange an RFID reader to show the RFID details of the modules transported to sites, to the site Engineer in charge up to their satisfaction, which is mandatory for the site acceptance test.
11. Each PV module used in any solar power project must use a RF identification tag (RFID), which must contain the following information. The RFID can be inside or outside the module laminate but must be able to withstand harsh environmental conditions.
12. The PV modules must qualify (enclose Test Reports/Certificates from IEC/NABL accredited laboratory) as per relevant IEC standard. The Performance of PV Modules at STC conditions must be tested and approved by one of the KEBS or ISO Accredited Testing Laboratories.
13. The PV modules shall have a minimum warranty of Twenty (20) years on performance and materials, with 10% degradation after 10-years (90% name-plate rated power capacity available

after 10-years) and 20% degradation after 25 years (80% name-plate rated power capacity available after 25-years).

14. Original Equipment Manufacturers (OEM) Warrantee of the PV Modules shall be submitted by the successful bidder when the materials delivered at site.

NOTE:

- I. The Engineer reserves the right to test the modules for qualification and performance characteristics with respect to these specifications. Performance characteristics established by the methods set out in the above specifications shall be used to verify the output of the modules to meet the system performance requirements.
- II. Each module shall have a unique serial number inside the module encapsulation (i.e. stickers with serial number are not acceptable). Also to be included within the encapsulation is the name of the project, name of client and date of manufacture of the solar module.

The acceptable tolerance shall be +5%-3% respectively for all modules supplied under this contract. The modules to be supplied shall comply with or even perform better to the following temperature coefficients:

- $a_{P_{mpp}}$: - 0.6%/°C
- $a_{V_{mpp}}$: - 100mV/°C
- $a_{I_{sc}}$: +2mN °C
- $a_{V_{oc}}$: -1 00mV/°C SPV cells in each module

Each module shall be assumed to deliver nominally 1000VDC with the maximum power DC voltage of minimum 37.5VDC.

Modules shall be suitable for operation in high temperature environment. The minimum number of series-connected cells in each mono- or poly-crystalline module shall be 72 cells for 1000VDC modules and 60/72 cells for 24V modules.

5.2 Terminal connection box

Each module shall be provided with weatherproof terminal connection box (es) to IP54 rating, with robust screws of metallic (not plastic) composition.

5.3 Bypass diodes

Bypass diodes shall be installed to prevent hot-spots in modules, which occur often as a result of partial shading of modules.

Every module in a series configuration of 24/48V or higher nominal voltage shall include bypass diodes in the module terminal-connection box. The diodes shall be replaceable without replacing the module or module junction box.

5.4 Labelling and marking of PV Modules

The SPV Modules shall be clearly labelled and permanently marked with a data plate containing the following information:

- manufacturer's name and physical address;
- type/model number;
- serial number;
- the watt-peak power rating at STC
- Open circuit voltage and short circuit current
- Voltage and current at maximum power point
- Tolerance and temperature coefficient
- the date of manufacture and country of manufacture
- Certification, e.g: IEC 61215, ISO certification etc

The module terminals shall be clearly marked as positive (+) and negative (-) so as to avoid reverse polarity problems.

NOTE: For purposes of this contract, solar-Pv modules shall be specifically marked in way that, the serial number, model number, the date of manufacture, the name of the project and the name of the Client shall be clearly visible, embedded within the encapsulation of the module or engraved on top with indelible (non-erasable) marks.

5.5 .Mechanical properties

The frame of the SPV modules to be supplied shall be made from corrosion resistant anodized aluminium alloy to ensure dependable performance even under harsh weather conditions. Pre-drilled holes for fixing of modules onto the mounting frame with bolts shall be provided for ease of installation.

Bolts and nuts for fastening solar modules

The bolts and nuts or screws to be used to fasten the solar modules on to the mounting rack shall be of the secure type (theft inhibiting screws), which prevent (or make it very hard) theft of solar modules. The nuts should be self-sealing or require a special key to open.

Example of a theft-inhibiting screw:

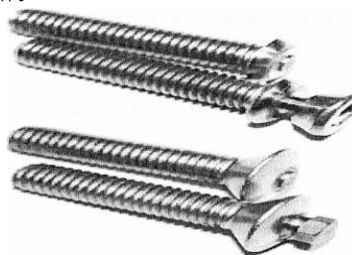

Self-sealing bolts

5.6 PV Module Installation and Accessories

PV module interconnection

Wiring shall be permanently shaded from UV radiation. Wiring shall be 'Flexible multi-strand copper conductor cables in flexible UV resistant (e.g. Neoprene) sheath compatible with gland seals', with array junction boxes as may be required.

The arrangement of modules on the structure and their interconnection shall be designed to enhance servicing and inspection:

Blocking diodes

- 24V modules will considerably simplify array wiring. Modules shall first be connected in series strings of individual modules to achieve the desired nominal voltage (i.e only if 12V modules are used), and these strings shall be paralleled to develop the required peak current. For modules connected in series, connections from each module shall be looped from one module terminal-connection box of one module to the next.
- No more than one cable per gland shall be allowed unless conduit is used, and the cable/conduit entries shall be watertight.
- When modules or strings of modules are thereafter connected in parallel, practical wiring constraints require that at least one array junction box is used, and modules/strings at the correct voltage are connected to the array junction box.

A blocking diode assembly is required only if the regulator requires blocking diodes. If they are required, then blocking diode assemblies complete in array junction boxes shall be supplied.

5.7 Array junction box:

Each series string of modules of an array of three or more parallel strings of modules shall be individually connected to a weather-proof array junction box.

The junction box shall be capable of dissipating the heat generated by the blocking diodes (if installed). The array junction box shall be to IP54 rating.

The junction box shall be provided with internal DIN-rail type electrical connectors. The terminals shall be clearly labelled positive or negative/DC-IN/DC-OUT. The type of wiring and arrangement of wiring within the junction box should facilitate maintenance and inspection of connections. There shall be one full loop within the array junction box, for each incoming and each outgoing cable.

Junction boxes must be accessible, securely and squarely mounted on the array structure, out of easy access range of tampering and whenever possible in the shade of the PV array.

5.8. Voltage configuration for Solar Panel (sub-array).

A voltage configuration of 500-1000VDC, or higher as appropriate [with reference made to inverter/controller input DC voltage requirements] shall be used for construction of a sub- array.

5.9. Module or Array Mounting

The array support structure shall be fixed (non-tracking), after installation. The tilt angle to the horizontal must be in the range between 10° to 15° after installation on the relevant location.

The structures shall withstand wind speeds of 120km/hr. The structure shall be ground mount and all materials used with the associated standard of works, shall comply with the specifications for rust-free/corrosion resistant metal works.

The structure shall be corrosion resistant galvanized steel, hot-dipped galvanized to thickness, and the panels shall be attached to the structure in four places.

The contractor shall supply all necessary nuts, bolts, washers etc for mounting the array to the super-

structure, and for mounting the super-structure to the vertical pole.

All nuts, bolts and washers shall be stainless or galvanised steel, and any other mounting material shall be of corrosion resistant material.

The bolts for fixing the modules onto the structure should be stainless tamper-proof bolts.

5.10 Installation of Array Structure

Orientation and tilt of the PV array

- The structure shall be orientated to the south, although this might not be critical. The installer shall note the deviation of magnetic north from true north. The array shall tilt at least 10-15 degrees and not more than 15 degrees from horizontal, to allow water and dust to freely wash off the array.
- Photovoltaic arrays must be mounted on a stable, durable structure that can support the array and withstand wind, rain, and other adverse conditions. The modules will be fixed on structures with fixed arrangement.
- The module mounting structures shall have adequate strength and appropriate design suitable to the locations, which can withstand the load and high wind velocities. Stationary structures shall support PV modules at a given orientation, absorb and transfer the mechanical loads to the surface properly.
- Each structure with fixed tilt should have a tilt angle as per the site conditions to take maximum insolation which will be approximately equal to the latitude of the location facing true South with a North - South orientation. The tilt angle can vary from 9 degree to 12 degree based on the location's latitude in Kerala
- The PV module mounting structure shall have a capacity to withstand a wind velocity of 150 km/hr unless specified for dedicated requirements
- Suitable fastening arrangement such as grouting and calming should be provided to secure the installation against the specific wind speed. The PV array structure design shall be appropriate with a factor of safety of min 1.5.
- The materials used for structures shall be Hot dip Galvanized Mild Steel conformed to IS 2062:1992 or aluminium of suitable grade minimum alloy 6063 or better.
- The minimum thickness of galvanization for hot dip Galvanized Mild Steel should be at least 80 microns as per IS 4759.
- The Bolts, Nuts, fasteners, and clamps used for panel mounting shall be of Stainless Steel SS 304.
- No Welding is allowed on the mounting structure
- Aluminium structures used shall be protected against rusting either by coating or anodization.
- Aluminium frames should be avoided for installations in coastal areas.
- The structure shall be designed to withstand operating environmental conditions for a period of a minimum of 25 years. And shall be free from corrosion while installation.
- Screw fasteners shall use existing mounting holes provided by module manufacturer. No additional holes shall be drilled on module frames
- The total load of the structure (when installed with PV modules) on the terrace should be less than 60 kg/m²
- Minimum distance between the lower level of PV Module and the ground shall be 0.6m from the

ground level.

- The PV Panel area shall be accessible for cleaning and for any repair work.
- Sufficient gap need to be provided between the rows to avoid falling of shadow of one row on the next row. Seismic factors for the site will be considered while making the design of the foundation.
- Adequate spacing shall be provided between any two modules secured on PV panel for improved wind resistance.
- Installation of structure for solar PV mounting should not tamper with the water proofing of the roofs

6.0 QUALITY OF INSTALLATION

1. **Ground Mounting structure:** Ground mount structures shall be reinforced.

Note: The structure should provide enough headroom for the parking space under the structure suitable for car parking i.e. 3 m headroom.

2. **Roof mount structures:** Roof mount structures shall be attached to purlins using through-roof J-bolts. J-bolts to penetrate roof only on high point of corrugations, and to use sealed compression glands on both inside and outside to prevent leakage. Alternatively, anchored threaded studs to be drilled to maximum 10mm (do not understand 10mm) so as not to pierce roof shield, and cause leakage.

Note: Roof Structure to be examined for structural agility to take the loads proposed from the solar loading.

Repairing damage made: Any surface damage to galvanising shall be treated with either Galvadip™, Adensotape™ or Petrotape™ systems, or other approved cold-galvanising treatments.

Any holes made in the roof material shall be sealed and made waterproof with approved UV resistant material.

Array junction box and wiring: The array junction box must be mounted squarely and accessibly on the array mounting structure.

Wiring shall be UV resistant and should be shaded where possible, or protected with UV-resistant or painted conduit.

Array structure earthing: PV module frames and array structures shall be properly earthed.

6.1 Solar array (PV) disconnects switch

For PV-direct systems, a two-pole disconnect switch must be installed between the solar array and the controller. The loading of the switch shall not exceed 70% of the nominal capacity-this will allow for system expansion. The switch shall comply with relevant clauses of the IEEC/IEC and UNBS standards for DC electrical systems.

6.2 Electrical wiring

All electrical wiring shall be in accordance to the IEC/IEE and UNBS standards for Photovoltaic systems. Specific clauses of US152: 2000 sections 4.0 and 5.0, shall respectively apply to all DC-wiring requirements, including all cabling, terminations and voltage drops. A voltage drops exceeding 3% of nominal supply voltage across each input/output system component shall not be permissible.

6.3 Cables and Interconnections

a) Cables

All cables shall be UL type TC, 600V, 90°C with PVC sunlight resistant jacket and include corrosion resistant, non-metallic, liquid-tight cable strain relief connectors or approved KEBS equal, with overall lengths pre-sized for best appearance.

Two-wire cable assemblies are red and black conductors used for 12V system parallel connections on 24V or 48V systems. Three-wire assemblies red/black/blue conductors used for 24/48V series/parallel connection of the last module in a 4-panel assembly. Four-wire assemblies red/yellow/blue/black used for 415VAC 3-phase system.

b) Interconnections

An important part of the system wiring is proper module connection that exhibits the highest degree of reliability and performance in severe climates and environmental conditions.

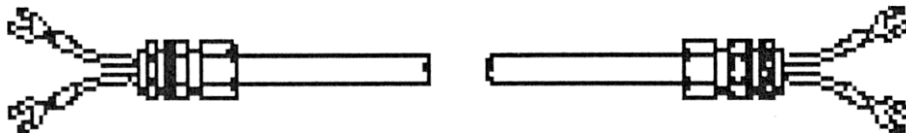

FIG: Cable Interconnects - illustrates a standard module interconnection accessory.

Figure: Cable Interconnects

All such interconnections shall be pre-assembled, featuring tin-plated copper fork terminals for stud, crimped and soldered to AWG stranded copper wire with adhesive "melt-wall" shrink tubing heat sealed over the crimp connection or an equally approved interconnection.

7.0 SOLAR METER and NETMETER

Solar Meter:

A separate Energy Meter called Solar Meter shall be provided at the output of PCU to record the energy generation from the Solar System. (This energy meter should not be integrated with PCU). Solar energy meter means a unidirectional meter to be installed at the delivery point of the solar energy system to measure the solar electricity generated. This Energy Meter should be tested along with the Net Meter (Import-Export Meter).

Net meter:

As per Energy & Petroleum Regulatory Authority (EPRA) Regulations 2012, net metering system is to be provided to the solar consumer. Net meter means the bidirectional energy meter to be installed at the interconnection point of the consumer with the network of distribution licensee

Energy meters shall be installed and maintained in accordance with the provisions of (EPRA) as amended from time to time. The Contractor shall maintain the Metering System as per metering code and Kenya Power guidelines. The defective meter shall be immediately tested and rectified/replaced.

A solar meter and bidirectional energy meter suitable for the installed solar plant shall be supplied and installed by the contractor after testing and sealing from respective chambers. Energy Meters must be provided with the necessary data cables if required.

The solar energy meter and net energy meter shall be of accuracy as given and CT and PT shall be utilized according to Kenya Power metering regulations and its amendment.

Meters shall be microprocessor based conforming IEC 60687 / IEC 6205211 / IEC 62053-22/ IS 14697 and solar energy meter or its display shall be placed adjacent to net energy meter.

Display parameters: LCD test, kWh import, kWh export, MD in kW export, MD in kW import, Date & Time, AC current and voltages and power factor (Cumulative kWh will be indicated continuously by default & other parameters through push-button). The solar energy meters and net energy meters should be DLMS compliant and AMR compatible with RS 485 communication port for measurement of specified electrical parameters.

The solar energy meters shall be provided with two ports for communication of the measured/ collected data. One port compatible with RS 485 specifications, which shall be used for remote access through suitable GPRS modem and the other port shall be an optical port complying with hardware specifications detailed in IEC 62056-21.

8.0 GROUNDING AND LIGHTNING PROTECTION

8.1 Grounding and bonding

All the structural components and electrical enclosures shall be bonded together to a common earth connection. When connecting dissimilar metals, connectors that are approved for the materials involved should be used. (Example: at the aluminum framework of the solar array, connectors labelled "AL/CU" are used).

8.2 Earth connection

An effective discharge path for the surge should be created. One or more 8-foot (2.5m) copper-plated ground rods, preferably in moist earth, should be installed. Where the ground gets very dry (poorly conductive, #6 (16 sq. mm) or double #8 (10 sq. mm) or larger bare copper wire shall be buried in a trench at least 100 feet (30m) long. Connection to one end to the array structure and controller should be done or, the ground wire should be cut in half and spread in two directions.

8.3 Lightning Protection

The lightning arrester and associated equipment supplied for this purpose shall be in accordance with the IEC/IEE regulations. The external and the internal protection require a good earthing system to evacuate the lightning currents, and equal potentiality within the earthing system, both protection system and of the electrical circuits to be protected.

Lightning arrestors of type Fast response Silicon Oxide Varistor in potted PVC case may as appropriate be used or copper arrester with the copper tape and ground rod are recommended for use.

Note: Determine whether the existing lightning arrester systems installed recently are sufficient for the new solar installations under consideration

Surge protection.

For the electrical system has to be implemented by using a single-pole surge arrester with rated line-neutral operating voltage of 275Vac, voltage protection level at 5kA is 1kV, with 25ns response time; certified to IEC 61643-1 standard.

9.0 BATTERY

- a. Capacity of the battery bank should be designed in such a manner that the energy stored in the battery should cater to a loads of 100%.
- b. The Batteries should be only Lithium Ion or Supercapacitors type.
- c. Relevant IEC Standards should be referred to during designing the battery bank. Below is list of IEC/IS specifications for the battery specification.
- d. IS 1651 & IS 13369, Stationary lead-acid batteries – Vented types – General requirements and methods of test.
- e. IS 15549, Stationary Valve regulated lead-acid batteries specification. IS 15767 (2008) / IEC 62259, Secondary cells and batteries containing alkaline or other non-acid electrolytes- Nickel cadmium prismatic secondary single cells with partial gas recombination.
- f. Depth of discharge is limited to 70%.
- g. The typical charge and discharge currents are the following: - Maximum charge current: C/10 A - Average discharge current determined by the load: C/120 A.
 1. NOTE 1- Depending on the system design, the charge and the discharge current may vary in a wider range.
 2. NOTE 2- In some systems the load current must be supplied at the same time as the battery charging current

Period of high state of charge

Typically, batteries will be operated at high state of charge between 80 to 100% of rated capacity unless batteries & systems are not properly sized. The system designer should choose the maximum charge voltage of the battery (as applicable to each battery technology) as a compromise allowing to recover to a maximum state of charge (SOC) as early as possible in the seasons other than the monsoon but without substantially overcharging the battery. The overcharge increases the gas production resulting in water consumption in vented cells. In valve regulated lead acid cells, the overcharge will cause a lesser increase of water consumption and battery internal temperature there by reduction in battery life. Typically, the maximum charge voltage is 2.4 V per cell for lead-acid batteries and 1.55V per cell for vented Lithium Ion batteries (refer manufacturers recommendations). These values are applicable for the reference temperature specified by the manufacturer. For the other batteries the values shall be given by the battery manufacturers. Charge voltage compensation shall be used according to the battery manufacturer instructions if the battery operating temperature deviates significantly from the reference temperature. The expected life-time of a battery in a PV system even kept regularly at a high state of charge may be considered less than the published life of the battery used under continuous float charge.

The following standards shall apply:

- IEC 61427-1 Standard: Secondary cells and batteries for solar photovoltaic energy systems - General requirements and methods of test.
- IEC 62093 Draft standard: Balance of system components for photovoltaic systems-design qualification natural environments.

Installation: Installation of batteries shall be in accordance with the relevant clauses of US152: 2000 and IEC standards listed above.

10. THE DC-AC INVERTER

The following parameters shall hold over the entire range of operating voltage and loading ranges:

- The hybrid Inverter system shall be preferred with the MPPT "Maximum Power Point Tracking" system to enhance the efficiency of solar conversion and energy backup.
- The nominal RMS voltage per phase to be 230 V AC, 1 +/-5% at a input voltage range between 90% and 120% nominal input voltage-with pure sine wave out.
- The output frequency shall be 50Hz +/- 5% pure sine-wave.
- Efficiency not less than 95%.
- Operate safely for at least one minute at 125% of rated power.
- Provide at least 200% of rated power for at least two 2 seconds.
- The output waveform total harmonic distortion should be no more than 3%. The inverter supplied should be of the transformer type.
- The maximum quiescent current draw of the inverter, when no LEDs are illuminated, must not exceed 3% of the rated input current of the inverter.
- Quiet operation: The noise produced by the inverter should be no more than 65dB at a distance of 3 meters from the inverter.
- The inverter shall be protected against failures due to:
 - over-load; low battery voltage
 - over-temperature condition
 - output short-circuits
 - reverse input polarity
 - Lightning induced transients when use in lightning-prone areas is expected.
- The inverter shall clearly indicate at least the following conditions:
 - on / standby mode
 - over-load / output short-circuit
 - low battery voltage
- The inverter input and output terminals must not be exposed to contact by the user and must be securely mounted in a location which is not accessible by children.
- Each inverter must be labelled with the minimum information:
 - Manufacturer name and model, Serial number
 - Input and output voltage and rated power
 - Battery and load connection points and polarity
- Complete documentation for the inverter must be included in the service technicians training manual and should include:
 - Installation instructions, Operating instructions
 - Safety warnings, Troubleshooting instructions
 - Information pertaining to serviceable parts; and Warranty
- The contractor shall submit in the technical bid manufacturer's specifications and other relevant information to support the listed specifications for the inverter as proof of compliance.

11.0 AC SYSTEM SPECIFICATIONS

Though the solar system pre-dominantly produces DC power, for universality of loads and ease of operations, the Client recommends AC power for all sockets and lamps. Hence, an inverter has to be employed to convert DC to AC power; and as such, all house wiring has to be of AC-standard.

12.0 ARRAY JUNCTION BOX (AJB) / STRING COMBINER BOX (SCB)

AJB shall be provided as per the design requirement of the Inverter, if required. AJB comprises of an enclosure, copper busbars, Fuses, Surge Protection Device (SPD) and Isolator. DC generated by the solar modules is transmitted through the appropriate cables from Array Yard to Control facility. AJB bus & panel shall be provided for the incoming DC supply from array yard.

AJB, if required, should be equipped with an adequate capacity indoor DC circuit breaker along with control circuit, protection relays, fuses, etc.

AJB, if required, shall have sheet from enclosure of dust and vermin proof, the bus bar / cables are to be made of copper of desired size.

The Array Junction Boxes are to be provided in the PV array for termination of connecting cables. The Array Junction Boxes shall be made of GRP/FRP/with full dust, water& vermin proof arrangement. All wires/cables must be terminated through cable lugs. The JB's shall be such that input & output termination can be made through suitable cable glands.

- 11.1. Suitable markings shall be provided on the bus bar for easy identification and the cable ferrules must be fitted at the cable termination points for identification.
- 11.2. Copper bus bars/terminal blocks housed in the junction box with suitable termination threads conforming to IP 65 standard to prevent water entry, Single/double compression cable glands, provision of earthing. It should be placed at a height suitable for ease of accessibility.
- 11.3. Each Junction Box shall have high quality Suitable capacity Metal Oxide Varistors (MOVs)/ SPDs. The Surge Protective Device shall be of Type 2 as per IEC 60364- 5-53
- 11.4. The junction Boxes shall have suitable arrangement for the followings (typical):- Combine groups of modules into independent charging sub-arrays that will be wired into the controller. The Junction Boxes shall have arrangements for disconnection for each groups and attest point for sub-group for fault location. AJB/SCB shall be wired with optical fibre cables for enabling data collection for PV Plants from 100kWp onwards.
- 11.5. The current carrying ratings of the string combiner box/ junction box shall be suitable with adequate safety factor, to inter connect the Solar PV array.
- 11.6. All fuses shall have DIN rail mountable fuse holders and shall be housed in thermoplastic IP65 enclosures with transparent covers.
- 11.7. Fuse for both positive and negative inputs of each strings, Isolator of MCB, SPD of type 2 shall be provided.
- 11.8. The surge arresters shall be type 2 (with reference to IEC 61643-1) rated at a continuous operating voltage of at least 125 percentage of the open-circuit voltage of the PV string, and a flash current of more than 5A.
- 11.9. Not more than two strings can be connected in parallel to a single input of SCB/AJB. One spare input terminal along with connector shall be provided for each SCB/AJB.

- 11.10. Every SCB/AJB input shall be provided with fuses on both positive and negative side.
- 11.11. DC switch disconnecter of suitable rating shall be provided at AJB/SCB output to disconnect both positive and negative side simultaneously.

12.0 AC DISTRIBUTION BOARD

AC Distribution Board (ACDB) shall control the AC power from inverter and should have necessary surge arrestors.

An ACDB panel shall be provided in between PCU and Utility grid. It shall have MCB/MCCB/ACB or circuit breaker of suitable rating for connection and disconnection of PCU from grid.

- 12.1 The connection between ACDB and Utility grid shall be of standard cable/ Conductor with suitable termination. It shall have provision to measure grid voltage, current and power.
- 12.2 The incomer shall be selected at required rating. The ACDB enclosure shall be of good protection and suitable for mounting on the trenches / on wall.
- 12.3 All the 415 V AC or 230 V AC devices/equipment like bus support insulators, circuit breakers, SFU isolators (if applicable), SPD, etc. mounted inside the switch gear shall be suitable for continuous operation
- 12.4 Switches/ circuit breakers/ connectors meeting general requirements and safety measurements as per IS 60947 Part I, II, III and IEC 60947 part I, II and III.
- 12.5 Junction boxes, enclosures, panels for inverters/ Controllers shall meet IP 54 (for outdoor)/ IP 65 (for indoor) as per IEC 529.

13.0 AC /DC CABLING

Cabling is required for wiring from AC output of inverter/PCU to the Grid Interconnection point. It includes the DC cabling from Solar Array to AJB and from AJB to inverter input.

- 13.1. All cables of appropriate size to be used in the system shall have the following characteristic:
 - a. Shall conform to IEC 60227 / IS 694 & IEC 60502 / IS 1554 standards.
 - b. Temperature Range: -10 degree Celsius to +80 degree Celsius
 - c. Voltage rating: 660/1000V
 - d. Excellent resistance to heat, cold, water, oil, abrasion, UV radiation
 - e. Flexible
- 13.2. Sizes of cables between any array interconnections, array to junction boxes, junction boxes to inverter etc. shall be so selected to keep the voltage drop (power loss) of the entire solar system to the minimum (2%).
- 13.3. The length of exceeding 25m of AC cable from Inverter to ACDB and to the Grid connection point shall be borne by the customer.
- 13.4. For the DC cabling, XLPE or XLPO insulated and sheathed, UV stabilized single core flexible copper cables shall be used; Multi-core cables shall not be used.
- 13.5. For the AC cabling, PVC or XLPE insulated and PVC sheathed single or, multi-core flexible copper cables shall be used. However, for above 25kWp systems, XLPE insulated

Aluminium cable of suitable area of cross section can be used in the AC side subject to a minimum area of cross section of 10 sq.mm. Outdoor AC cables shall have a UV -stabilized outer sheath IS/IEC 69947.

- 13.6. All LT XLPE cables shall conform to IS:7098 part I&II.
- 13.7. The total voltage drop on the cable segments from the solar PV modules to the solar grid inverter shall not exceed 2.0%
- 13.8. The total voltage drop on the cable segments from the solar grid inverter to the building distribution board shall not exceed 2.0%
- 13.9. The DC cables from the SPV module array shall run through a UV-stabilized PVC conduit pipe of adequate diameter with a minimum wall thickness of 1.5mm
- 13.10. Cables and wires used for the interconnection of solar PV modules shall be provided with solar PV connectors (MC4) and couplers
- 13.11. All cables and conduit pipes shall be clamped to the rooftop, walls and ceilings with thermo-plastic clamps at intervals not exceeding 50cm; the minimum DC cables size shall be 4.0mm² copper; the minimum AC cable size shall be 4.0mm² copper. In three phase systems, the size of the neutral wire size shall be equal to the size of the phase wires.
- 13.12. Cable Marking: All cable/wires are to be marked in proper manner by good quality ferule or by other means so that the cable can be easily identified. The following colour code shall be used for cable wires
 - a) DC positive: red (the outer PVC sheath can be black with a red line marking)
 - b) DC negative: black
 - c) AC single phase: Phase: red; Neutral: black
 - d) AC three phase: phases: red, yellow, blue; neutral: black
 - e) Earth wires: green
- 13.13. Cables and conduits that have to pass through walls or ceilings shall be taken through PVC pipe sleeve.
- 13.14. Cable conductors shall be terminated with tinned copper end ferrules to prevent fraying and breaking of individual wire strands. The termination of the DC and AC cables at the Solar Grid Inverter shall be done as per instructions of the manufacturer, which in most cases will include the use of special connectors.
- 13.15. All cables and connectors used for installation of solar field must be of solar grade which can withstand harsh environment conditions including high temperatures, UV radiation, rain, humidity, dirt, salt, burial and attack by moss and microbes' for 25 years and voltages as per latest IEC standards. DC cables used from solar modules to array junction box shall solar grade copper (Cu) with XLPO insulation and rated for 1.1 kV as per relevant standards only.
- 13.16. Bending radii for cables shall be as per manufactures recommendations and IS: 1255.
- 13.17. For laying/termination of cables latest BIS/IEC Codes/ standards shall be followed.

14.0 CIVIL WORKS

Existing shade-free roof-top space shall be used to install Solar PV array. While installing solar power plants on rooftops, the physical condition of the rooftop, chances of shading, chances water level rise in the rooftop during raining due improper drainage in the roof-top should be taken in to consideration.

- 14.1. PV array shall be installed in the terrace space free from any obstruction and/or shadow and to minimize effects of shadows due to adjacent PV panel rows.
- 14.2. PV array shall be oriented in the south direction in order to maximize annual energy yield of the plant.
- 14.3. The solar PV array must be installed on the rooftop in such a way that there is sufficient space on the rooftop for maintenance etc.
- 14.4. There should not be any damage what so ever to the rooftop due to setting up of the solar power plant so that on a later day there is leakage of rainwater, etc. from the rooftop.
- 14.5. Some civil works are inevitable for erecting the footings for the module mounting structure as discussed in Module Mounting Structure section. The roof top may be given a suitable grading plaster with suitable leak proof compound so as to render the roof entirely leak proof.
- 14.6. Ample clearance shall be provided in the layout of the inverter and DC/AC distribution boxes for adequate cooling and ease of maintenance.
- 14.7. While cabling the array, care must be taken such that no loose cables lie on the rooftops.
- 14.8. The roof top should look clean and tidy after installation of the array.
- 14.9. Neatness, tidiness and aesthetics must be observed while installing the systems.
- 14.10. RCC Works - All RCC works shall be as per IS 456 and the materials used viz. Cement reinforcement, steel etc. shall be as per relevant IS standards. Reinforcement shall be high strength TMT Fe 415 or Fe 500 conforming to IS: 1786-1985.
- 14.11. Brick Works (If any) - All brick works shall be using 1st class bricks of approved quality as per IS 3102.
- 14.12. Plastering - Plastering in cement mortar 1:5, 1:6 and 1:3 shall be applied to all.
- 14.13. Display of mandatory items- Single Line Diagram and layout diagram of modules and interconnection at installation site shall be provided near the inverter for greater than 10 kWp systems.
- 14.14. For painting on concrete, masonry and plastered surface IS:2395 shall be followed. For distempering IS 427 shall be followed referred. For synthetic enamel painting IS 428 shall be followed. For cement painting IS 5410 shall be followed.
- 14.15. All Civil works required for the installation of the PV Plant and other civil and electrical work in evacuation infrastructure, wherever necessary, shall be within the scope of the bidder
- 14.16. The layout of Inverter accommodation shall be designed to enable adequate heat dissipation and availability. Mount within the existing infrastructure available in consultation with the Site in charge. String Inverters may be installed with Canopy type structure over it to protect it from frequent monsoon and weather changes.

15.0 WARRANTY

The contractor shall as well furnish warranty certificates for each major component (solar- PV modules, Inverter) obtained from the equipment manufacturers. The warranty certificates for solar-PV modules and inverters shall be Twenty-Five (25) years, five (5) years and Two (2) years respectively.

It should be noted that solar-PV modules shall have guaranteed capacity for minimum 25- years, such that, 10% degradation is expected after 10-years (available power output is 90% of rated capacity after 10years) and 20% degradation is expected after 25 years (available power output is 80% of rated capacity after 25 years).

The successful bidder should submit the copies of the Warrantee Certificates for the on- site warrantee provided by the OEM for the important components like PV Modules, Inverters, Junction Boxes etc.

16.0 OPERATION MANUAL

An Operation, Instruction and Maintenance Manual, should be provided with the system. The following minimum details must be provided in the manual:

- About solar power plants – its components and expected performance.
- DO's and DON'T's
- Cleaning of Solar PV Modules in regular intervals
- Clear instructions on regular maintenance and troubleshooting of solar power plant
- AS built Drawings for the Installation
- OEM Warrantee Certificates of Inverters, PV Modules, Batteries etc.
- Specification of PV Plant
- Data Sheets of major equipment like PV Module, Inverter etc.
- Name and address of the Solar PV Contractor and the contract person in case of non- functionality of the solar power plant.

SECTION 5

PART 2

PARTICULAR SPECIFICATIONS

FOR

SOLAR PV INSTALLATIONS

TABLE OF CONTENT

1.0	Background.....	2
2.0	Scope of Work.....	3
3.0	Particular Specifications Of The Main Solar Pv System Components.....	4
4.0	Solar PV Module Mounting structures and Civil Works.....	8
5.0	Drilling and Cutting.....	9
6.0	Actual Route of Cables and Conduits.....	9
7.0	Cable tray/ladder for both AC & DC cables.....	9
8.0	Earthing and Bonding.....	9
9.0	Smart Monitoring Platform.....	9
10.0	Site Inspection.....	10
11.0	Drawings and Documents.....	10
12.0	Commissioning and Completion of the Facilities.....	11

SECTION 5-2: PARTICULAR SPECIFICATIONS

1.0 BACKGROUND

Work under this section shall include the supply of materials, installation, commissioning, testing and delivery in perfect running conditions of the 31.6kWp Rooftop Mounting Solar Power System for Mtwapa Branch, in most effective and efficient manner in accordance with the entire requirements of contractual agreement to the full stratification of Client / electrical engineer.

The approximate Solar PV capacity to be supplied will be 31.6kWp, 3 – 10kWac Hybrid Inverters, 92.2kWh (@80% DOD) Lithium Ion/ Super Capacitor battery storage system.

The 35.1kWp Solar Rooftop Photo Voltaic (SPV) power plant consists of SPV array, Module Mounting Structure, Power Conditioning Unit (PCU) consisting of Maximum Power Point Tracker (MPPT), Inverter, and Controls & Protections, interconnect cables, MC4 connectors, Junction boxes, Distribution boxes and switches. PV Array is mounted on a suitable structure. SPV system is with battery backup and should be designed with necessary features. Components and parts used in the SPV power plants including the PV modules, metallic structures, cables, junction box, switches, PCUs etc., should conform to the BIS or IEC or international specifications, wherever such specifications are available and applicable. The Rooftop Mounting Solar Power System installations comprise, but are not limited to the followings items:

- Solar PV modules consisting of required number of Crystalline PV cells.
- Energy Storage, Battery Backup (Battery Bank)
- Inverter, Charger Controller, Control Panel and Junction Boxes
- Roof Top Mounting Structures
- IR/UV Protected Cabling, Conduits and fittings
- Grounding, Earthing and Lightning Protection Systems
- Complete installations

The supply shall include all the equipment, accessories and other materials not enumerated in these specifications but found necessary for the completion and perfect functioning of the installations of roof top mounting solar power system for successful execution and completion of the project.

Electrical works and solar system installations shall be executed in a first-class work-manlike manner in accordance with these specifications, the drawings and notes indicated therein, the instructions of Client /Engineer, the provisions of the Bill of Quantities delivered in place and tested to the full satisfaction of the Client / Engineer

2.0 SCOPE OF WORK:

- a) Design review of a solar PV system that will serve various users within the branch premises
- b) The Plant Capacity will be 31.6kWp Solar PV, 92.2kWh battery storage and 3-10kWac Hybrid inverters.
- c) The installation must adhere to applicable local and international standards, ensuring compliance with regulations. Additionally, aesthetics is a key consideration, and the system should be visually appealing.
- d) Perform necessary analysis and estimate annual power generation.
- e) Supply of PV modules, inverter(s), storage systems, mounting structure, cabling, mounting hardware, distribution connection works, meteorological equipment. PV modules, inverters and storage systems should be preferably supplied from Tier One suppliers. The contractor shall provide details of the manufacturer and the technical specifications for each item of equipment included in the design and quotation. This shall include details for all components/ parts of each installation; panels, inverter, storage including material to be used in the mounting structure. Please provide only one manufacturer/supplier for each item of equipment.
- f) All designs including but not limited to civil works, solar power generator and electrical works must be agreed with the Consultant/Bank upon award and prior to commencement of the contract. The contractor shall be responsible for all design works and ensuring that all installations function correctly in accordance with these designs. The contractor shall be responsible for any systems that do not function correctly as a result of improper design and/or improper workmanship. The contractor shall also clearly specify the warrantee of the system and the specific warrantees and guarantee for the main equipment namely panels, inverters and storage system.
- g) The contractor's minimum warranty requirement for the main equipment is as follows;
 - i. Panels and Roof Structure - 25years
 - ii. Inverters - 10years
 - iii. Storage System - 10yrs
 - iv. Defects Liability period / Workmanship Warranty - 1 year
- h) The contractor shall guarantee minimum warranty for the workmanship and installation up to and including the DLP period.
- i) All installations shall be designed and installed to facilitate inspection, cleaning and maintenance and to ensure continued operation under conditions prevailing at the site. The contractor will be responsible for verification of data provided necessary for design
- j) Installation and commissioning of Solar PV system.
The Contractor shall include for all associated civil and construction works necessary for the complete installation of all equipment, including but not limited to excavations, concrete works, backfilling, earth ramming, and foundations. Pricing, designs and specifications for these works

shall also be fully detailed in the Schedule of materials. The contractor shall submit preliminary design documentation, including the string design and wiring.

- k) The roof space above the branch premises or such other surfaces as may be practical, will be used to mount the solar panels. In addition, to secure the plant, an electric fence will be installed or as shall be advised by the client. The works and costs associated should be well captured.
- l) The contractor shall provide operational and maintenance services of the solar system for a period of twelve months after commissioning the project.
- m) The contractor will be liable for the entire clearing process and delivery of materials to the site including all applicable taxes payable to the Government and associated logistics.
- n) The Contractor will be responsible for acquiring the environment impact assessment approvals and all relevant operational licenses from the County Government, where applicable.
- o) Defect liability period shall be twelve (12) months from the date of commissioning and hand-over to the client.
- p) Manufacturer's authorization for all major equipment should be submitted alongside other mandatory requirement indicated under the evaluation criteria. Refer to appendices for Manufacturer's Authorization and Warranty Form.
- q) Upon negotiations and award, the contractor will be required to present a performance bond with validity for the entire contract period.

3.0 PARTICULAR SPECIFICATIONS OF THE MAIN SOLAR PV SYSTEM COMPONENTS

3.1 Solar PV Modules

The specifications below is a basic guide and the contractor may propose a better and higher rated performance solar module to suit the final solar system capacity.

- Nominal Power Rating - 585 W
- Allowable power rating range - 550W-595W
- Cell type - N-type monocrystalline
- Back Glass - Heat Strengthened Glass
- Junction Box - IP68 Rated
- Frame - Anodized Aluminum alloy
- Parallel Capability/Modular - Yes
- Maximum System Voltage - 1500VDC (IEC)
- Maximum Power Voltage - 42.59V
- Open Circuit Voltage - 51.47V
- Maximum Power Current - 13.62A
- Short Circuit Current - 14.37A
- Power Tolerance - 0±3%
- Operating Temperature - -40°C ~+80 °C

- Nominal Operating Cell Temperature - 45±2 °C
- Module efficiency (STC) - 22.45°C

The Solar PV modules shall be from Tier One manufacturer and complies with IEC 61558.

As a guide, the following make /models are listed as a guide an any other equivalent alternatives shall be have to be approved in writing by the Bank before award;

- i. Jinko
- ii. Canadian
- iii. JA Solar
- iv. Trina
- v. Any other equal and approved make/model. Approval shall be strictly by the Client/Consulting Engineer

3.2. Three Phase Hybrid Inverter System

The contractor to provide the specification/data sheet with the details of following parameters which are the main specifications of the inverter unit:

(i) Battery Input

- Battery type Lithium –ion
- Parallel Capability Supported
- Battery Voltage range (v) 160-700v
- Maximum Charging Current (A) 37A
- Maximum Discharging Current (A) 37A
- Charging Strategy for battery Self adaption to BMS
- Power Rating 10,000W
- AC Voltage Regulation (Battery Mode) 230 VAC + 5% @ 50 Hz
- Surge Power 10000VA
- Efficiency (Peak) ≥92%
- Waveform Pure Sine wave
- Transfer Time ≤10ms

(ii) PV String Input

- Max DC Input Power(W) 13000
- PV input Voltage(V) 550 (150~800)
- MPPT Range(V) 200~650
- Start-up Voltage(V) 160
- PV input current(A) 26+13
- Max. PV ISC(A) 34+17
- No of MPPT Trackers 2
- No of Strings per MPPT Tracker 2+1

(iii) AC Input/output

- Rated Ac Output and UPS Power(W) 10,000
- Max. Ac Output Power(W) 11,000
- Peak power (off grid) 2 times of rated power, 10s
- Ac Output Rated Current (A) 15

- Max. Ac current (A) 23
- Max. Continuous passthrough (A) 50
- Output Frequency and Voltage 50/60Hz; 230/400Vac(Three phase)
- Grid type Three Phase
- Current Harmonic Distortion THD<(Linear load<1.5%)
- Efficiency
- Max. Efficiency 97.60%
- Euro Efficiency 97%
- MPPT Efficiency 99%

(iv) Battery

Battery Voltage 48V
 SNMP V2c/v3 #MIB Template for integration with Solar Winds monitoring tool.

(v) Efficiency

Max. Efficiency 97.6%
 MPPT Efficiency >99%

(vi) Equipment Protection

- PV input Lightning Protection: Integrated
- Anti-islanding Protection: Integrated
- PV String Input Reverse polarity protection : Integrated
- Insulation Resistor Detection: Integrated
- Residual Current Monitoring Unit: Integrated
- Output over current Protection: integrated
- Output shorted protection: Integrated
- Output Over voltage protection: Integrated
- Surge Protection: DC Type 11/AC type 11

(vii) Interface

Communication Interface – RS485/RS232/CAN
 Monitor Mode - GPRS/Wi-Fi, Bluetooth/4G/LAN (optional)

(viii) General

Operating Temperature Range (°C) -40 to +60°C, >45°C Derating
 Noise (dB) ≤55
 Ingress Protection (IP) Rating IP65
 Safety/EMC Standard State relevant IEC/EN Standards
 Warranty 10 years after Commissioning

As a guide, the following make /models are listed as a guide an any other equivalent alternatives shall be have to be approved in writing by the Bank before award;

- i. Deye / Jinko
- ii. Huawei
- iii. Victron

3.3. Battery Module / Unit

The battery specification, shall have the features outlined below:

- 48V,4800wh lithium battery rack to give at least a minimum of 12hrs runtime at 2.5 kW Load
- Nominal capacity [wh] 4800wh
- Rated voltage – 48V
- Discharge voltage [V] 44.8V – 55.2V
- Charge Voltage [V] 54.7V-55.2V
- Charge Mode CC-CV
- Discharge / Charge current [A] -50A
- Peak Discharge current [A] $130 \leq I \leq 200A @ 10\text{sec}$; $200 \leq I < 300A @ 3\text{sec}$; $300 \leq I \leq 600A @ 1\text{sec}$
- Maximum continuous discharge power 5Kw @25°C, > 10min
- Cell operation temperature [C] -20°C -60°C (discharge)
- Ambient temperature range [°C] Recommended -10°-40°C
- Cycle time 3000cycles,SOH >70%, 25°C± 2°C,1C 90%DOD
- 5000cycles,SOH >70%, 250C± 20C,0.5C 80%DOD
- Communication ports RS485,CAN
- Scalable
- Store temperature [Oc] 0°C- 35°C
- Humidity 5%- 95%
- Cooling Natural Cooling
- IP rating IP43(Minimum)
- Remote Monitoring unit. The unit shall have OPEN ended protocol to connect / integrate with the other sites countrywide and monitored centrally at Kencom House
- Certification UN38.3

As a guide, the following make /models are listed as a guide an any other equivalent alternatives shall be have to be approved in writing by the Bank before award;

- i. Deye/Jinko, BYD
- ii. Huawei- Lithium Valley
- iii. Greentech, Tesla
- iv. Any other equal and approved make/model. Approval shall be strictly by the Client/Engineer

3.4. Battery Enclosures (both indoor and Outdoor)

Battery storage cabinets should have the following specifications to ensure the safe storage and charging of batteries:

- **Fire protection:** Cabinets should be made of fire-resistant materials and be rated to withstand internal fires for at least 90 minutes.
- **Temperature monitoring:** Cabinets should have temperature monitoring to prevent overheating.
- **Charging protection:** Cabinets should have overcharge protection mechanisms.
- **Ventilation:** Cabinets should have sufficient ventilation to dissipate heat and ensure adequate air circulation.

- **Lockable doors:** Cabinets should have lockable doors to control access to the batteries.
- **Grounding:** Cabinets should have a grounding attachment.
- **Shelves:** Cabinets may have fixed or perforated shelves.
- **Fire extinguisher:** Cabinets may have an integrated fire extinguisher.

Note: Lithium-ion batteries are especially hazardous because they contain a flammable liquid electrolyte. Improperly charging or storing them can lead to: fire or explosion, thermal runaway, and release of toxic gases

The customized cabinet shall comply with the following specifications;

- Galvanized Steel frame
- Color RAL7035/Pantone428C,powder coating finish
- Storage temperature -50°C~+70°C
- Air pressure 62kpa~101kpa
- Ingress Protection IP55 IP65
- Noise Level 60-65dB
- Cooling 1500W,AC220V Air conditioner+DC48V fans
- Working temperature -40°C~+55°C
- Cable Entry at the bottom
- Floor Mounted
- External size 1800*800*500mm and modular to accommodate the various sizes of storage

4.0 Solar PV Module Mounting Structures and Civil Works

The civil works for the proposed Solar PV rooftop System shall include, design of the Roof Top Solar PV mounting frame structures and installation. The PV modules shall be mounted on fixed metallic structures having adequate strength and as per requirement of site to withstand the load of the modules and high wind velocities. the mounting structure should be facing south direction tilted at 34degree and Rooftop Module Mounting structure must be designed accordingly. It should be able to withstand 90 km/hr wind speed and support the installed solar PV modules, ensuring the roof remains water proof, stability and wind withstanding capacity. The Contractor must provide the technical design and drawing of the PV mounting structure.

Regarding existing building structures, the contractor need to take care of the load bearing capacity of the roof and need arrange suitable structures based on the quality of roof. The total load of the structure (when installed with PV modules) on the terrace should be less than 60 kg/m². The array structure shall be grounded properly using maintenance free earthing kit suitable for mounting over building terrace.

5.0 Drilling and Cutting

The Contractor shall have to do all drillings and cutting of roof, walls, ceilings or other parts of the building for the complete proper installation of the mounting support structures, conduits, cables, switchboards and other parts of equipment.

Beams, girders and other principal structural members shall not be cut or drilled unless permission has been granted by the Structural Engineer employed by the Contractor.

If such drilling and cutting is made on finished surfaces, any marring of the surface shall be made good by repair or replacement at the Contractor's expense.

6.0 Actual Route of Cables and Conduits

The location of conduits, cables, switchboards, cable trucking, etc.... is shown on the drawings approximately, therefore the actual route of cables and conduits may differ from the plans according to the details or the building construction and the conditions of execution of the installation.

The Contractor shall supply and install at his expense all secondary materials and special fittings found necessary to overcome the interference and to apply the modifications on the route of cables and conduits that are found necessary during the work to the complete satisfaction of the Engineer.

7.0 Cable tray/ladder for both AC & DC cables

The contractor shall ensure that the complete installation is carried out as per the specifications stated in the Part 1- General Specifications for

- Single Compartment
- Powder coated and galvanized
- Sleeves, bolts and nuts included

8.0 Earthing and Bonding

The Electrical contractor shall ensure that the complete installation is earthed and bonded in accordance with the requirements of the current edition including amendments of the Wiring Regulations as issued by the Institution of Electrical Engineers (IEE).

Particular attention should be paid to the provision of all equipotential bonding conductors, the earthing of extraneous metalwork and supplementary bonding.

9.0 Smart Monitoring Platform

The specified Smart Inverters has an in-built remote monitoring system.

However, the client requires an open ended platform which can connect upto 200 Solar PV sites on one platform, termed as PV management System.

PV Management System is a software application that is required to operate a complete system of solar power generation. The program works as a command and control centre for the solar PV system. It manages the entire process of setup, maintenance and operation of the PV system

The smart monitoring platform should support remotely shutdown immediately when accident occurs, setting parameters and forward update remotely, which makes PV plant O&M easier.

It should support the establishment, data collection, monitoring, operation, maintenance, and after-sales services for new energy power stations like photovoltaic, energy storage, and micro-inverters.

The smart monitoring platform should offer a variety of power station and equipment types, comprehensive monitoring, efficient troubleshooting, intelligent data analysis, energy flow visualization, and diverse management modes.

The smart PV monitoring solution is to ensure that the PV system is in excellent operation throughout its entire life-cycle.

This monitoring solution will provide details information of the power generating plant including Today/daily energy, Monthly energy, yearly energy, total energy etc, through wireless communication with bank branch router to the internet by an smart wifi plug.

User can easily access to the monitoring page via PC web or phone APP.

Main Features of the system shall include the following as a minimum;

- Step less inverter power and reactive power control and monitoring via communication.
- Universal interface to inverters, power meters and generator controllers.
- Simulation for calculating and training in a safe environment.
- Consumption, production and PV performance monitoring and reporting.
- Alarms and reports via email.
- Available as DIN rail mounted or as a ready-to-use solution

The Contractor should state if the license for proposed system software is a one-off purchase or renewable annually.

10.0 Site Inspection

Once empaneled and when a project is awarded the Contractor should visit site / sites for the checking the feasibility before proceeding.

11.0 Drawings and Documents

Once empanelled and when a project is awarded the contractor must submit drawings/documents required by the client and obtain the approval before the installation.

- i. Schematic drawing showing the PV panels, Power conditioning Unit(s)/Inverter, Array Junction Boxes (AJBs)/String Combiner Boxes (SJB), AC and DC Distribution Box, Net meters, MSB etc.
- ii. Layout of Solar PV Array
- iii. Single Line Diagram (SLD) with specification of all components.
- iv. Design document for Module Mounting Structure (MMS) including certificate showing wind speed withstanding capacity of the structure (STAAD/Equivalent)
- v. Module Mounting Structure (MMS) drawing along the foundation details for the structure

- vi. Sizes and specification of cables for PV Module interconnections, PV Array to Array Junction Boxes, Array Junction Boxes to Inverter, Inverter to ACDB/ Grid Connection point etc. shall be furnished.

In addition to the client/Engineers design information provided, the contractor shall carry out independent site survey and submit a PVsyst report for PV power plants to be implemented on site as working drawings. All PV plant design should contain the following details which should be approved by the concerned officer before installation.

- i. Design of strings including the number of PV modules in series and number strings
- ii. AC Protection (Circuit Breaker, Switches, Fuses, SPD)
- iii. DC Protection (Switches, Fuses, SPD)
- iv. AJB/SCB details
- v. DC Cable size and length from point to point
- vi. AC Cable size and length from point to point
- vii. Earthing system details and number of pits
- viii. Lightning protection details/ specification
- ix. PV Syst Simulation Report

11.0 Commissioning and Completion of the Facilities.

As soon as installation of the Facilities has, in the opinion of the Contractor, been completed as specified in the Technical Specifications, excluding minor items not materially affecting the operation or safety of the Facilities, the Contractor shall so notify the Bank in writing to witness the pre-commissioning of the facility.

As soon as all works in respect of Pre-commissioning are completed and, in the opinion of the Contractor, the Facilities is ready for Commissioning, the Contractor shall so notify the Bank in writing. The Contractor shall commence Commissioning of the facilities.

Commissioning of the Facilities shall be completed by the Contractor as per procedures detailed in the Technical Specifications and in the presence of the electrical engineer or the representatives of the Bank.

If the Bank notifies the Contractor of any defects and/or deficiencies, the Contractor shall then correct such defects and/or deficiencies, and shall repeat the procedure.

If the Bank /Engineer is satisfied that the Facilities have reached Completion, the Bank electrical engineer shall, within seven (7) days after receipt of the Contractor's repeat notice, issue a Completion Certificate stating that the Facilities have reached Completion as at the date of the Contractor's repeat notice.

If the Bank electrical engineer is not so satisfied, then it shall notify the Contractor in writing of any defects and/or deficiencies within seven (7) days after receipt of the Contractor's repeat notice, and the above procedure shall be repeated.

As soon as possible after Completion, the Contractor shall complete all outstanding minor items so that the Facilities are fully in accordance with the requirements of the Contract, failing which the

Employer will undertake such completion and deduct the costs thereof from any monies owing to the Contractor.

Upon Completion, commissioning and successful demonstration and submission of the test results, the contractor shall be responsible for the care and custody of the Facilities, together with the risk of loss or damage thereto, and shall thereafter take over the Facilities or the relevant part thereof for the agreed duration of operation and maintenance as stipulated and mutually agreed terms and conditions.

SECTION 6:
BILLS OF QUANTITIES

BILLS OF QUANTITIES

The Bank is desirous of considering two options of financing the implementation of the works.

- Option A - Outright Purchase
- Option B – Lease to Own within specified period of either 3, 5 or 7 years.

OPTION A– OUTRIGHT PURCHASE MODEL PROPOSAL

1. The Design and Schedule of Materials is provided as per the Schedule of Materials and the general notes below shall apply:

- 1.1 The total of the prices in the summary of prices shall include for the whole of the Contract works in accordance with the specifications as defined before and shall be carried forward to Form of Tender.
- 1.2 Any prices omitted from any item, section or part of the price schedule shall be deemed to have included in another item, section or part.
- 1.3 The specification should be priced in Kenya Currency i.e Shillings and cents.
- 1.4 Labour, overheads, profits etc. costs shall exclude VAT where applicable and shall be expressed in Kenya Shillings.

All rates entered in the bills of quantities shall exclude VAT. There shall be a component of VAT on the summary page.

- 1.5 The Contract is for supplying, delivering, fixing/installing, testing, commissioning and setting to work to the full satisfaction of the Engineer and the Contractor's price must include all cost for the entire process.
- 1.6 The Contractor shall ensure that the highest standards of workmanship and highest quality materials are used at all times. Inferior workmanship and low quality materials shall be rejected and replaced at the Sub-contractors own cost.
- 1.7 The Contractors shall be solely responsible for the correct and accurate ordering of materials in accordance with the drawings and Bills of Quantities.
- 1.8 No claims on advance payment and/or materials off-site will be allowed unless the Contractor advances valid reasons acceptable to the employer. Should a claim on advance payment be allowed, the sub-contractor will be required to submit an Advance Payment Bond for the full value claimed.
- 1.9 This is a fixed price sub-contract, and the Contractor is expected to allow (in his unit rates) for generous fore-casts on fluctuations. Unless otherwise provided in these bills of quantities, the rates and prices quoted by the tender shall not be subject to adjustment during the performance of the Contract on account of price fluctuations or fluctuations in the rate of exchange of the various currencies.
- 1.10 The Bills of Quantities shall be read in conjunction with Notes to All Tenderers, Preliminaries, General Specifications, Particular Specifications and all the relevant drawings.
- 1.11 General directions and descriptions of work and materials are not necessarily repeated nor summarized in the Bills of Quantities. Reference to the relevant sections of the sub-contract document shall be made before entering prices against each item in the priced Bills of Quantities.
- 1.12 Provisional sums and contingencies included and so designated in the Bills of Quantities shall be expended in whole or in part at the direction and discretion of the Engineer.

OPTION B– KCB SOLAR POWER LEASE TO OWN MODEL PROPOSAL

The general notes in Option A shall apply in addition to the following;

KCB seeks to consider a lease-to-own solar installation program for its physical infrastructure. In this model, the Bank installs a solar photovoltaic system with no upfront costs but gradually pays for it over time and eventually owning the system.

Under this agreement, the Bank shall lease the PV solar system for a duration (either 3, 5, 7 or 10 years) during which they shall make fixed payments.

Upon conclusion of the Term, the ownership of the solar system shall automatically transfer to the customer.

1. **Financing:** The provider shall be expected to get a financing partner to cover the upfront costs of the solar photovoltaic system.
2. **Design and Installation:** The solar system shall be installed as per the designed specifications to meet the energy requirements of the premises
3. **System Monitoring:** The provider shall provide system performance monitoring to ensure that the system is operating efficiently.
4. **Agreement:** The bank shall sign a lease agreement with the provider outlining the agreed terms, conditions
5. **Monthly Payments:** The bank shall make fixed rate monthly payments over the agreed period (either 3, 5 or 7 years) with no escalations. The payments shall be effective when the system becomes operational.
6. **Operations and Maintenance:** The provider shall be responsible for all systems operation and maintenance throughout the lease period.
7. **Insurance:** The system Insurance shall be on account of the provider until the end of the lease term.
8. **Ownership:** At the end of the lease term, the solar equipment ownership shall revert to the bank.
9. **Early Buyout:** The provider shall outline early buyout options if any.

Lease-to-Own	3-Year Option	5-Year Option	7-Year Option
Fixed Quarterly (every 3-Months) Fee (KES)			

Statement of Compliance

- a) I confirm compliance of all clauses of the General Conditions, General Specifications, Particular Specifications, Technical Specifications in this tender.
- b) I confirm I have provided / attached all the required data sheets as required in the Bills of Quantities and summarised below

Technical Data Sheets

SN	Component	Description:	Bidder Remarks
1	Solar PV Modules	<ul style="list-style-type: none">• Total Size of Array must be at least as provided• Individual Solar PV Module must be 585watts or above• The proposed Solar PV Module must comply with the latest IEC type tests. A list of IEC type tests are mentioned below.	
2	Energy Storage (Battery Bank)	<ul style="list-style-type: none">• Total Size of Battery Bank must be at least the size specified in the BOQ• Maximum allowed parallel string connection is two, it is important to be chosen the right individual battery capacity that will give suitable form the battery bank.• The proposed Battery must comply with the latest IEC type tests. A list of TEC type tests are mentioned below	
3	Inverter	<ul style="list-style-type: none">• Total Size of inverter should be not less than the size mentioned in the BOQ• Inverter Type: Hybrid• The proposed inverter must comply to the latest IEC type tests. A list of IEC type tests are mentioned below.	

4	Mounting Structure/Frame	<ul style="list-style-type: none"> • MS-hot dip Galvanized support structures to be fixed on the roof of the building. The galvanization thickness should adhere to ASTM 123. • Mounting structure must be designed such that it is installed to have solar PV array towards due south around local latitude at 34 degree with horizontal space • The support frame structure should be able to resist at least 25 years of outdoor exposure without suffering significant damage or corrosion. • It shall support solar PV modules at a given orientation, absorb and transfer the mechanical loads to the ground properly. The structure should withstand a windload of 90 KMPH 	
5	Installation materials	<ul style="list-style-type: none"> • As required following national/international standards 	
6	Earthing Protection and	<ul style="list-style-type: none"> • As required following NS/ IS standard • Battery management system should be a part of the system. • The solar PV plant structure shall be grounded properly using adequate number of earthing kits. All metal casing of the system shall be thoroughly grounded to ensure safety of the Solar PV system. • The Solar PV system shall be provided with lightning and over voltage protection. • The main aim in this protection shall be to reduce the over voltage to a tolerable value before it reaches the system. • The system should have protection against battery overcharge and deep discharge conditions. • Fuses should be provided to protect against short circuit conditions. • Full protection against open circuit, accidental short circuit & reverse polarity should be provided. • The earth resistance value should be less than 5 	

7	Cables and conduits	<ul style="list-style-type: none"> • As required following NS/ IS standard • Outdoor cables must be UV protected • Cables must be selected to ensure voltage drop across it must not exceed 3% 	
8	System Voltage	<ul style="list-style-type: none"> • Installing company can design the system voltage as per requirement and technical correctness. The system voltage should be compatible to solar PV module, Inverter, Charge Controller and Battery Bank 	
9	Wiring Restructuring	<ul style="list-style-type: none"> • The existing wiring to be checked and ensure that circuit for outlets are separated. • Circuit for heavy high consumption electrical appliance such boiler, air conditioners must be separated. • In consultation with Branch staff the circuits for essential and non-essential appliance should be speared. Load segregation of the building will be the responsibility of the contractor. 	
10	Remote Monitoring System /Platform	<ul style="list-style-type: none"> • Bidder to attach data sheets for proposed system 	

Signed:for and on behalf of the Tenderer

Date:

Official Rubber Stamp:

KCB BANK KENYA LTD
PROPOSED BANK BRANCH SOLARIZATION PROGRAM - MTWAPA BRANCH
SCHEDULE OF BILL OF QUANTITIES

BILL NO.1 - PRELIMINARIES AND GENERAL CONDITIONS

ITEM NO.	DESCRIPTION	UNIT	QTY	RATE (KES)	AMOUNT (KES)
1.1	Allow for provision of performance bond equivalent of 10% of the contract sum on award of the contract.	Item	1		
1.2	Allow for Insurance of the works and the system installed until it is handed over to the Bank either at the end of Defect Liability Period for outright purchase or at lapse of the agreed lease period in accordance with the Conditions of Contract. Insurance during construction works will include WIBA and All Risk.	Item	1		
1.3	Allow for presentation and approval of samples by the Client/Engineer including data sheets/physical samples for panels,batteries, inverters,cable management system, remotes monitoring unit etc	Item	1		
1.4	Allow for site visit after award of tender for verification of design data and generation and preparation of construction drawings for Client/Engineers approval before commencement of works.	Item	1		
1.5	Allow for engagement of a qualified and registered Structural Engineer to carry out detailed structural analysis of the roofing structure with respect to the proposed solar installation and issue an authenticated professional report on the structural integrity of the roof structure, how to address and remedy any noted weakness.	Item	1		
1.6	Allow for execution of works after the official working to minimise interference with operations of the branch including during integration of the solar PV system to the existing power supply system of the branch.	Item	1		
1.7	Allow for statutory approvals of the project. This includes but not limited to the following:-				
	(i) County Government Approvals	Item	1		
	(ii) NCA and NEMA (where applicable)	Item	1		
	(iii) EPRA and/or Kenya Power (where required)	Item	1		
Total For Bill No. 01 Carried Forward to Summary Page					

BILL NO. 2 - SOLAR PV SYSTEM

ITEM NO.	DESCRIPTION	UNIT	QTY	RATE (KES)	AMOUNT (KES)
	<p>Supply, deliver to site, install, test and commission the following as per particular technical specifications or approved equivalent</p> <p>It is MANDATORY for the vendor to go through the particular specifications of every item as described in the tender document's TOR</p> <p><u>SOLAR PANEL - TIER 1 Solar PV Module (Solar Panel)</u></p>				
1	<p>585W_p solar mono-crystalline Tier 1 /A-Grade/updated N-type technology photovoltaic module as per the stated particular specifications therein as Jinko, Huawei,JA Solar, Trina or approved equivalent by the client/engineer (Approximate Total system power requirement is 31.6 kWp).</p>	No	54		
	<p><u>HYBRID GRID INVERTER SYSTEM</u></p>				
2	<p>10.0 kW, 1000V three phase, transformerless, smart storage hybrid inverter with 2 MPPT points(2+1) DC inputs. The inverter shall support parallel connection and shall have an ingress protection of IP65 for outdoor mounting as per the stated particular specifications therein as Deye/Jinko, Huawei, Victron or approved equivalent by the Client/Engineer.</p>	No	3		
3	<p><u>Solar PV String Junction Box</u></p>				
3.1	<p>Custom made Solar PV String Junction Box comprising of the following:</p> <p>(i) 1No. IP 66 polycarbonate enclosure with DIN rail mounting accessories, and cable terminal blocks</p> <p>(ii) 30A, 100VDC gPV fuse disconnecter as Schneider, ABB or equal and approved make by the client/engineer</p> <p>(iii) 2 Pole 40kA 1000VDC Surge Protection Device (SPD) Type 2 as Schneider, ABB or equal and approved make.</p>	No	1		
		No	6		
		No	6		
3.2	<p>2 Pole 30A 1000VDC Switch disconnecter c/w rotary handle in an IP66 Enclosure as Schneider, KATKO, ABB or equal and approved make .</p>	No	6		
5	<p><u>DC Cabling - Between Solar PV Array, DC Junction Box and Inverter</u></p>				
5.1	<p>2x6.0 sq.mm single core PVC/PVC UV protected copper cable from the solar pv strings to the Solar PV String junction box complete with cable lugs and glands.(NOTE: 1 Lm means 2 lengths of positive and negative cable)</p>	Lm	300		
5.2	<p>2x6.0 sq.mm single core PVC/PVC UV protected copper cable from the Solar PV string Junction box to the inverter(NOTE: 1 Lm means 2 lengths of positive and negative cable)</p>	Lm	50		
5.3	<p>Single Core 75.0 sq.mm welding/auto cable interconnecting the inverters, the battery bank and battery bank DC bus complete with cable lugs and glands as manufactured by Metsec,East Africa, Coast Cable or approved equivalent by the Client/Engineer.</p>	LM	30		
Sub -Total Carried Forward to Next Page					

ITEM NO.	DESCRIPTION	UNIT	QTY	RATE (KES)	AMOUNT (KES)
	Sub -Total Brought Forward from Previous Page				
	Supply, deliver to site, install, test and commission the following as per particular technical specifications or approved equivalent				
6.0	<u>BATTERY BANK:</u>				
6.1	4.8KWh, 48Volts Tier 1 - Lithium-ion(LiFePO4) battery storage c/w the features outlined in the particular specifications therein as Deye/Jinko, Huawei, Greentech or approved equivalent by the Client/Engineer.	No	20		
7	<u>Battery Storage Cabinet</u>				
	Free standing, modular, Factory Assembled/ Custom made Battery Storage cabinet as per the stated particular specifications. The cabinet to accommodate the 20No. 100Ah battery capacity and should be housed in a vented compartment/stand that prevents users from coming in contact with battery terminals and complete with the following: Air Vent, Incoming cable glands, battery circuit breaker, monitoring interface, battery Control Unit(BCU), Fuses, slots for above battery modules, Communication cable outlet, Monitoring display Unit(MDU), carbon Monoxide gas sensor (optional) and document holder. IP rating shall not be less than IP54 and as manufactured by Schneider / ABB or approved equivalent	Item	1		
8	<u>Housing For the Inverters</u>				
8.1	IP 68 Custom made lockable wall cabinet made of powder coated 18swg steel with vents for air circulation to mount the inverters.	Item	1		
9	<u>A.C Distribution and Cabling</u>				
9.1	63A TPN, 4-pole, 3-position Manual By pass Switch complete with IP66 enclosure as KATKO, ABB, Schneider or equal and approved to interconnect the inverter output and output of the KPLC/Generator Changeover	No.	3		
9.2	63A TPN, 4-pole, moulded case Circuit Breaker/Isolator mounted between AC input and the Inverters as ABB, Schneider or equal and approved.	No.	3		
9.3	125A TPN, 4-pole MCCB Isolator mounted between incomers of KPLC/generator and Inverter, complete with IP66 enclosure as ABB, Schneider or equal and approved.	No.	2		
9.4	40kA, 4-pole Surge Protection Device as Schneider, ABB or equal and approved make.		1		
9.5	Custom made AC Output Distribution board as detailed below; (i) 125A, 4Pole, 10kA MCB Outgoing (ii) 3No. 63A, 4 pole, 10kA MCB , Type B, Incomers (iii) Earthing of the enclosure to IEEE/BS7671 standards	Item	1		
	Sub -Total Carried Forward to Next Page				

ITEM NO.	DESCRIPTION	UNIT	QTY	RATE (KES)	AMOUNT (KES)
	Sub -Total Brought Forward from Previous Page				
	Supply, deliver to site, install, test and commission the following as per particular technical specifications or approved equivalent				
10	AC cable comprising 5-core 25.0 sq.mm PVC/PVC Cu cable to the following connections, complete with lugs and brass cable glands with earth tag and shroud. (i) From the existing Meterboard/KPLC Supply to board described in 9.3 above (ii) From the board in 9.5 above to the 63A TPN manual changeover	Lm	40		
		Lm	100		
11	Custom made Inverter/Grid Supply AC Distribution board as detailed below; (i) 1No. 125A 4Pole, 10kA MCB Integral Isolator (ii) 3No. 63A, 4-pole, 10kA MCB , Type B (iii) 3No. 63A, 4-pole, 30mA RCCB , Type A (iv) 1No. 125A, 4-pole, 240/415V Contactor (v) Set Control relays and digital display of phases (vi) Three phase Solar Smart Meter, c/w current transformers (vii) Earthing of the enclosure to IEEE/BS7671 standards	Item	1		
12	AC cable comprising 5-core 16.0 sq.mm PVC/PVC Cu cable to the following connections, complete with lugs and brass cable glands with earth tag and shroud from the distribution board in (11) above to the existing ATS panel in the branch	Lm	40		
13	<u>Solar Panels Mounting Structure</u>				
13.1	Solar P.V flat roof mount system to carry 54No. 585 Watts PV modules at an angle of 30° consisting of aluminium rails, intermodule clamps and end clamps to secure the panels onto the rails.(Total PV array area is 148sqm)	kW	32		
13.2	50 x 50mm rectangular galvanized metallic 1 compartment trunking for DC cables from the PV panels on the roof. (the trunking to be spray painted to match the background against which it is installed)	Lm	100		
13.3	100 x 50mm rectangular galvanized metallic 2 compartment trunking for AC and communication cables (the trunking to be spray painted to match the background against which it is installed)	Lm	100		
13.4	Fibre Reinforced Plastic roof walk way system complete with mounting brackets, steel safety line along the walk way and anchor points. Preferred color is yellow	Lm	60		
13.5	Cage ladder to access the roof(roof height is approximately 8 meters) made from heavy gauge 6061-T6 aluminium alloy and to EN ISO 14122-4 standard with a minimum resistance of 1.5 kN	Item	1		
	Sub -Total Carried Forward to Next Page				

ITEM NO.	DESCRIPTION	UNIT	QTY	RATE (KES)	AMOUNT (KES)
	Sub -Total Brought Forward from Previous Page				
	Supply, deliver to site, install, test and commission the following as per particular technical specifications or approved equivalent				
14.1	Earthing and Bonding				
	Carry out comprehensive earthing and equipotential bonding of the entire installation as described below:				
	(i) 15mm Ø, 1500mm long solid copper earth rod c/w driving stud, coupling, and spike as Furse RC011 or approved equivalent	No	3		
	(ii) Earth rod to tape clamp type A as Furse CR108 or approved equivalent	No.	3		
	(iii) Concrete inspection earth pit Cat. No. PT 005 with 5 hole earth bar as Furse Cat. No. PT 006.	No.	1		
	(iv) 600mm x 600mm copper earth mat made from 25mm x 3mm copper tape at 300mm spacing, buried to permanent moisture level and complete with all clamps and 6m long 25mm x 3mm copper tape clamped to the down conductor, soil conditioning agents (marconite or bentonite) as necessary to achieve earthing resistance value below 5-Ohms	Lot	1		
	(v) Allow for earthing tests for the above and submission of the report to the engineer to BS7671 & BS62305 standards	No.	1		
	(vi) Bonding				
	Bonding and clamping to all metal work including water pipes, gas pipes, hand-rails, smatv system, window frames, cladding, metal roof, frame of the solar panels etc. and the main earth for the building.	Item	1		
	(vii) Single core 16sq. mm yellow/green earthing cable	Lm.	60		
	(vii) Single core 2.5sq. Mm yellow/green earthing cable for the frames of the panels complete with lugs for each of the 90 panels	Lm.	30		
14.2	Lightning Protection				
	Carry out comprehensive Lightening Protection as described below				
	(i) 2000mm x15mmØ multiple point pure copper AirRods/ Termination with spikes as Furse Part No. RA240 or approved equivalent	No.	2		
	(ii) Copper Air Rod Base as Furse Part No. SD105-H or approved equivalent	No.	2		
	(iii) Copper Junction Clamps for copper tape as Furse Part No. CN105-H or approved equivalent	No.	2		
	(iv) 25mm x 3mm Tinned Copper Tape as Furse TC230 or approved equivalent	Lm.	20		
	(v) Down Conductor 25mm x 3mm Tinned Copper Tape as Furse TC230 or approved equivalent	Lm.	40		
	(vi) Screwdown copper test clamp as Furse CT305 or approved equivalent	No.	2		
	(vii) 38mm Ø HG PVC conduits for drawing the down conductor above.	Lm.	40		
	Sub -Total Carried Forward to Next Page				

ITEM NO.	DESCRIPTION	UNIT	QTY	RATE (KES)	AMOUNT (KES)
	Sub -Total Brought Forward from Previous Page				
	Supply, deliver to site, install, test and commission the following as per particular technical specifications or approved equivalent				
15	Solar Panels Cleaning Equipment				
15.1	Booster pump as Dayliff DDP 50/65A, complete with valves	No	1		
15.2	25mm uPVC pipe complete with fittings	Lm	50		
15.3	Fabricate and install cage for the pump above underground water tank	Item	1		
15.4	3 core 2.5 sqmm PVC/PVC Cu cable from the main distribution board to the pump above	Lm	50		
15.5	20A SPN, IP 66 moulded case Isolator for the above pump.	No	1		
16	Load Segmentation (as shall be instructed on site by Client)				
	(i)Supply and Install 4-Way, 100Amp TPN Distribution board for critical loads	Item	1		
	(ii) Associated cabling comprising 100LMx10sq.mm S/C, 100LMx2.5sq.mm Twin with earth and 100LMx1.5sq.mm Twin with earth Cu cable	Item	1		
	(iii) Associated circuit breakers- 3x10A SP, 2x20AmpsSP and 2x45A TP MCBs	Item	1		
17.0	Electrical Termination and Configuration				
17.1	Works including paralleling/change-over and configuration for the inverter and associated cabling between the inverter and the battery bank, integration of the solar PV system supply to the existing branch electrical power system i.e the supply grid and generator supply interconnections. The inverter to be configured such that solar PV shall be the primary source, Battery bank secondary, grid as tertiary source and standby generator as the last option of power supply. There will be a bypass mechanism to ensure power supply to the branch is not interrupted in case of malfunction/system maintenance of any of the sources of power. The vendor to study keenly the power flow block diagram and single line diagrams provided.	Item	1		
18.0	<u>Monitoring Platform</u>				
18.1	Solar monitoring and communication system to allow for remote monitoring over internet/ethernet complete with router/dongle, monitoring application software , appropriate communication protocol(RS-485 or TCP/IP) and associated cabling as ENCombi ECpv2 and ECcube S M or L ,irradiation sensor (soluzione litemeter modbus pro), I/O Modules , Pilot SPM33 power meter or approved equivalent by the client/engineer. Refer to specifications therein. Vendor to include the cost associated with annual renewal of this monitoring service where applicable and its configuration.	Item	1		
18.2	Cat.6A 4-pair FTP cable for communication system above as SIEMONS or approved equivalent	Lm	50		
19	<u>Labelling, Identification and Notices</u>				
	(i) Notice indicating presence of PV system in the building in trafolyte to be mounted at the Meterboard and Main Distribution Boards	Item	1		
	(ii) Identification and warning labels in traffolyte on all equipment and cabinets	Item	1		
	(iii) Labelling of all Distribution Boards and their corresponding sub-circuits	Item	1		
	Sub -Total Carried Forward to Next Page				

ITEM NO.	DESCRIPTION	UNIT	QTY	RATE (KES)	AMOUNT (KES)
	Sub -Total Brought Forward from Previous Page				
	Supply, deliver to site, install, test and commission the following as per particular technical specifications or approved equivalent				
20	<u>Testing and Commissioning</u> Provide for testing and commissioning of the entire Installation complete with all accessories, interconnections, Controls, BMS link, activation and monitoring set-up and configuration and necessary programming and a test report as per the specifications therein.	Item	1		
21	<u>Documentation</u> Provide for completion documents, comprising Shop drawings, manufacturer's technical product catalogues, warranties, users manual, maintenance manuals, as installed drawings, test certificates, etc.	Item	1		
22	<u>Training</u> Provide for training of client personnel/users (At least 4No for 1 week)	Sum	1		
23	<u>Defects Liability Period - Maintenance</u> Provide for 12-months comprehensive maintenance from the date of practical completion, i.e maintenance and replacement of consumables, cleaning of panels, etc.	Sum	1		
	Sub -Total Carried Forward to Main Summary Page				

ITEM NO.	DESCRIPTION	UNIT	QTY	RATE (KES)	AMOUNT (KES)
	<u>MAIN SUMMARY PAGE</u>				
MS.1	Bill No. 1 - Preliminaries and General Conditions				
MS.2	Bill No. 2 - Solar PV System Installation				
	Sub-Total				
	Add 16% VAT				
	Total				
	Allow 10.0 % Contingency Sum to cover any unforeseen additional work eg additional roof support and reinforcement to be expended as directed by the Engineer or the Client				
	Grand Total for Design, Installation and Commissioning of 31.6 kW Solar System Carried Forward to The Form of Tender				

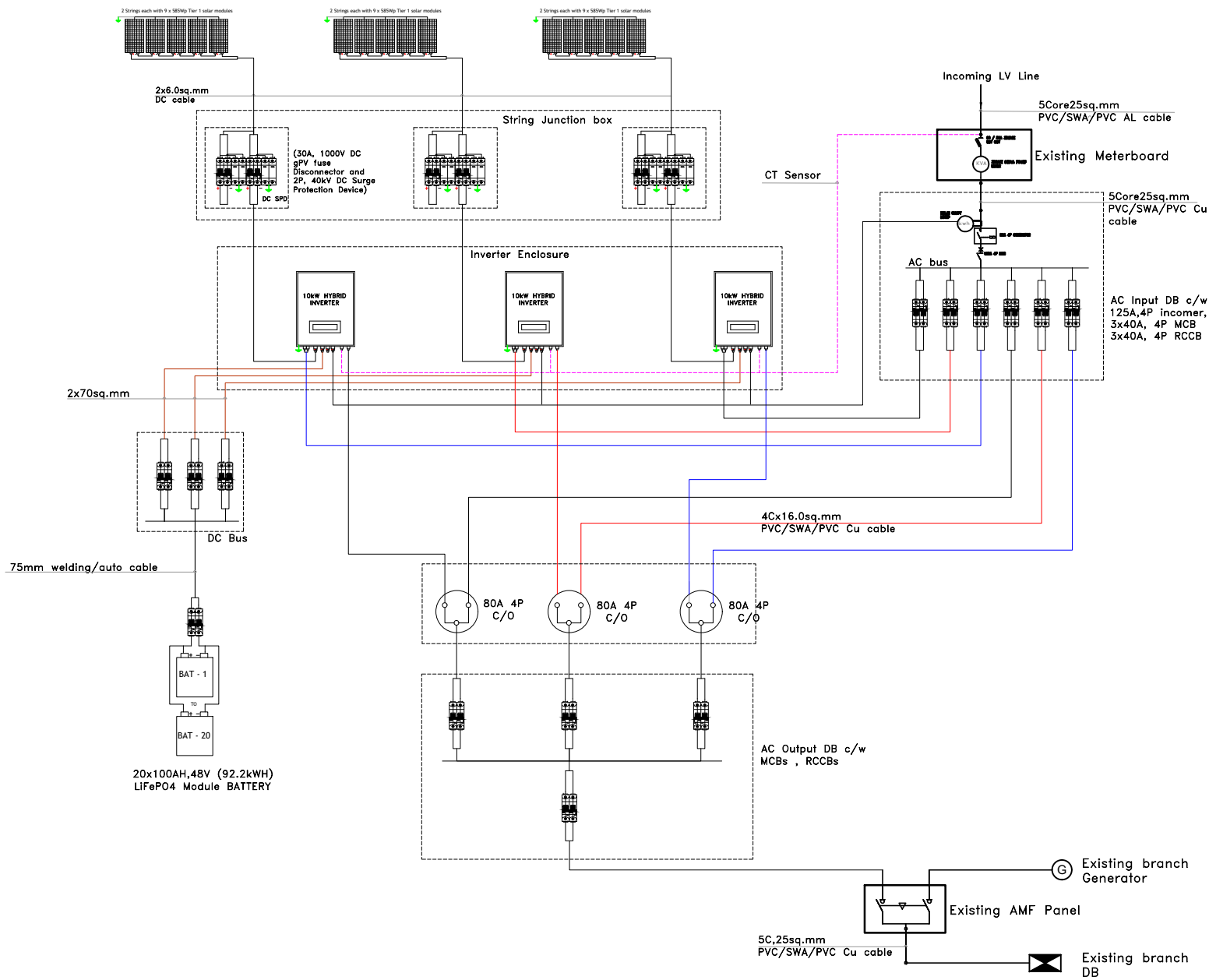

1 LEGEND

	REC Meter/Bi-directional Meter
	Solar Panel
	Inverter
	Surge Protection device (DC)
	AC/DC Breaker
	AC/DC isolator
	Surge Protection device (AC)

- 2 ELECTRICAL NOTES**
1. All Electrical works indicated shall be done in accordance with the latest provisions of IEE Electrical code, rules and regulations.
 2. All materials to be used shall be new and approved type for all location and purpose.
 3. All installations shall be done in neat and good workmanship.
 4. All electrical works shall be done under the direct supervision of Professional Electrical/Registered Electrical Engineer.

- 3 SOLAR ELECTRICAL NOTES**
1. Utility has 24 hours unrestricted access to all PV system components located at service entrance. Modules conform to and are listed under UL1703.
 2. Conductors exposed to sunlight shall be listed as sunlight resistance as per spec. Conductors exposed to wet location shall be suitable for use in wet location as per spec.
 3. New solar smart meter shall be installed in the new AC output Distribution Board.
 4. Tapping point for smart meter load side conductor shall be at the load visible. Disconnect device before service equipment. smart meter load side conductors shall be as short as possible.
 5. The line side conductors of the smart meter between the Grid tie inverter REC meter shall be exposed rigid metallic conduit or intermediate metallic conduit.
 6. Warning should be mounted on or adjacent to the visible disconnection device and shall be read prominently.

PROJECT NAME KCB BANK BRANCH SOLARIZATION PROJECT	CLIENT /OWNER KCB BANK KCB BANK KENYA LTD P.O BOX 48400-00100 NAIROBI	ARCHITECTS	MECHANICAL & ELECTRICAL ENGINEERS SERVCON ASSOCIATES LTD. Consulting MEP Engineers P.O Box 5602 00100 Nairobi Tel No. 0717 204060 Email: info@servcon.co.ke	PROJECT CODE	KCB	DRAWING NAME: SCHEMATIC FOR HYBRID SOLAR POWER	DATE	07.11.2024	
				PROJECT NO.	2024-338	MTWAPA BRANCH	SCALE		
						DRAWING NO: KCB-338-E-03	CHECKED	JK	REVISIONS
							APPROVED	SK	